

 **Titan** ACCELEROGRAPH **SMA**
User Guide

© 2017 Nanometrics Inc. All Rights Reserved.

This guide applies to all models of TitanSMA with firmware version 4.0.

The information in this document has been carefully reviewed and is believed to be reliable. Nanometrics Inc. reserves the right to make changes at any time without notice to improve the reliability and function of the product.

No part of this publication may be reproduced, stored in a retrieval system or transmitted, in any form or by any means, electronic, mechanical, photocopying, recording, or otherwise, without the prior written permission of Nanometrics Inc.

Nanometrics Inc.
250 Herzberg Road
Kanata, ON K2K 2A1
Canada

Toll free: +1 855-792-6776 (within North America)

Tel +1 613-592-6776

Fax +1 613-592-5929

Email sales_mkt@nanometrics.ca

www.nanometrics.ca

Contents

1.0 About the TitanSMA	10
1.1 Key Features	10
1.2 About Data Storage	11
1.2.1 Primary Media	11
1.2.2 Secondary (or Removable) Media	12
1.3 Cables and Accessories	12
2.0 Installation Tasks	15
2.1 Before You Visit the Installation Site	16
2.2 Choose a Deployment Option	16
2.2.1 Stand-alone Deployment	16
2.2.2 Networked Deployment	16
2.2.3 Data Access Options	17
2.2.4 Use Cases: Deployment and Data Access	19
2.3 Develop a Grounding Plan	19
2.3.1 Power	21
2.3.2 GNSS Antenna	21
2.4 About SD Media Cards	22
2.4.1 Insert SD Card	22
2.4.2 Remove or Swap the SD Card	22
2.4.3 SD Card Full or Corrupt	23
2.5 Perform the Initial Configuration	24
2.6 Perform a Tilt Test	24
2.7 Evaluate the Installation Site	24
2.8 What You Need for an Anchored Installation	26

2.8.1	Prepare the Installation Surface	27
2.8.2	Drilling Guidelines	28
2.8.3	Install and Anchor the TitanSMA	29
2.9	What You Need for a Freestanding Installation	31
2.9.1	Install a Freestanding TitanSMA	32
2.10	Post-installation Activities	35
2.10.1	Troubleshooting the Installation	36
2.10.2	TitanSMA Installation Checklist	37
2.10.3	Station and Device Information	38
3.0	Accessing the Web Interface	40
3.1	The Summary page	40
3.2	Direct Connection to the Web Interface	41
3.3	Network Connection to the Web Interface	41
3.4	Logging on to the TitanSMA Web Interface	41
3.5	About Passwords	42
3.5.1	Guidelines for creating a strong password	42
3.5.2	Changing the root password	42
3.5.3	Changing the Calibration Password	43
3.5.4	Changing the admin password	44
3.6	Configuring instrument security	44
4.0	Configuring Your TitanSMA	46
4.1	Downloading/Uploading the Configuration	46
4.2	General Configuration Settings	47
4.3	Accelerometer	48
4.4	Channel Naming	48

4.5 Communications	50
4.5.1 Discovery	50
4.5.2 Ethernet	50
4.6 Continuous Data Archive	51
4.7 Data Streaming	58
4.7.1 NP UDP/HTTP Streaming	59
4.7.2 Throttle	63
4.7.3 Fragmentation	63
4.8 Digitizer	64
4.8.1 Primary Channels	64
4.8.2 Secondary Channels	65
4.8.3 Bandpass Butterworth Filters	66
4.8.4 Trigger Input Filters	66
4.8.5 Trigger Detectors	67
4.9 Events	70
4.9.1 Events Data Archive	72
4.9.2 Trigger/Event Sharing	77
4.9.3 Event Data Products	78
4.9.4 Configure Email Notifications for Declared Events	79
4.10 Power	81
4.11 Raw TCP Receiving	82
4.12 SeedLink Server	84
4.13 State of Health (SOH) Settings	86
4.14 Timing Source	86
4.14.1 Sample Timing Configurations	88

4.14.2	Configuring GNSS timing	90
4.14.3	Configuring PTP timing	90
4.14.4	Guidelines for selecting an NTP server	91
4.14.5	Configuring NTP timing on a TitanSMA	91
4.14.6	Enabling a stratum 1 NTP server on a TitanSMA	92
4.14.7	Enabling a stratum 2+ NTP server on a TitanSMA	92
4.14.8	Timing Configuration Parameters	93
4.15	Location Configuration	95
5.0	Monitor the Status Indicator LEDs	97
5.1	Power LED	97
5.2	Link LED	98
5.3	Time LED	98
5.4	Media LED	99
5.5	Event LED	99
5.6	Overall Status LED	100
5.7	USB Eject LED	101
5.8	Media Eject LED	102
6.0	Using the Web Interface	104
6.1	Monitor the Status and Health of Your Instrument	104
6.1.1	Events	104
6.1.2	Device	106
6.1.3	Storage	107
6.1.4	Data	110
6.1.5	Time	111
6.1.6	Alerts	113

6.2	Event Detection and Declaration	114
6.2.1	View and Manage Events	115
6.2.2	Manually Declare Events	117
6.3	About Calibration	117
6.3.1	Calibrating your instrument	118
6.3.2	Creating a custom calibration signal file	119
6.3.3	Uploading a custom calibration signal file	120
6.4	View Digitized Waveforms in Near Real Time	121
6.4.1	View Waveform Data	121
6.5	Perform Maintenance Tasks	122
6.5.1	Setting Instrument Time	123
6.5.2	Upgrade Firmware	123
6.5.3	Retrieve Data from the Internal Storage	125
6.5.4	Download Log Files	126
6.5.5	Download Archive Files	126
6.5.6	Download Channel Response Files	127
6.5.7	Removable Media	128
6.5.8	Perform Maintenance on the Internal Storage	128
6.5.9	Restart/Shut Down a TitanSMA	129
7.0	Application Program Interfaces (APIs)	131
7.1	Data Availability API	131
7.2	Web Service data download interface (FDSN-WS)	137
7.3	Nanometrics data retrieval API	138
7.4	State of Health API	141
7.5	Instrument response API	142

8.0 Reference Information	144
8.1 Technical Specifications	144
8.1.1 Accelerometer Technology	144
8.1.2 Accelerometer Performance	144
8.1.3 Digitizer Performance	145
8.1.4 Calibration	147
8.1.5 Events	148
8.1.6 Communications	148
8.1.7 Data Recording and Retrieval	149
8.1.8 Timing	149
8.1.9 Physical	150
8.1.10 Power	151
8.1.11 Connectors	152
8.1.12 Environmental	153
8.2 Performance	154
8.2.1 Sensitivities	154
8.2.2 Frequency Response	155
8.2.3 Self-Noise	156
8.3 SOH channels in Steim compressed formats	157
8.4 Connectors and Pinouts	160
8.4.1 Ethernet Connector Receptacle and Pinout	160
8.4.2 Power Connector Receptacle and Pinout	161
8.5 Physical Features and Dimensions	162
8.5.1 Top View of the TitanSMA	162
8.5.2 Bottom View	163

8.5.3 Side View of the TitanSMA	164
8.5.4 View of the External Connectors	165
8.5.5 View of Open Media Bay	166
8.6 Open Source Attributions	167
8.6.1 Apache License	167
8.6.2 Bouncy Castle	167
8.6.3 BSD-2	167
8.6.4 COMMON DEVELOPMENT AND DISTRIBUTION LICENSE Version 1.0 (CDDL-1.0)	168
8.6.5 Eclipse Public License -v 1.0	172
8.6.6 GNU LESSER GENERAL PUBLIC LICENSE	175
8.6.7 Google Web Toolkit	177
8.6.8 X11 license (MIT license)	177
About Us	178
Contact Us	178

1.0 About the TitanSMA

The TitanSMA is a strong motion accelerograph used for high precision observational and structural engineering applications, where scientists and engineers require exceptional dynamic range over a wide frequency band. The integrated digitizer and recorder facilitate both standalone and networked monitoring deployments.

1.1 Key Features



- Intuitive Web interface
- Low noise floor, extremely low hysteresis, and industry leading dynamic range
- Data retrieval via a removable **SD**¹™ card or local Ethernet in [MiniSEED](#) and [ASCII](#)² file formats
- Continuous streaming of data to a central server, retrieved on demand or retrieved via a removable SD media card

¹Secure Digital

²American Standard Code for Information Interchange

- Real-time data streaming over Ethernet using SeedLink or Nanometrics Protocol (NP)
- Device configuration and control via a Web browser over an Ethernet connection
- **LED**¹ indicators that provide quick visual instrument status
- Ultra low latency configurations as low as 0.25 seconds
- Local real-time processing and transmission of **PGA**² data
- Network integration of multiple sensors for event triggers and voting
- Internal 8 GB redundant storage (expandable up to 64 GB in TSMA3– models)
- Precision timing with built-in GPS/GNSS or network timing using PTPv1 (Precision Time Protocol) or NTP (Network Time Protocol)
- TitanSMA can provide network timing to other Nanometrics instruments including other TitanSMA units, TitanEA or Centaur.

1.2 About Data Storage

Understanding how and where TitanSMA stores data will help you plan and implement effective [data access](#) for your deployment.



In a networked deployment, in the unlikely event of both an internal media failure and a prolonged communications failure, it may be possible to recover some data from a continuous archive on the SD card. Please contact techsupport@nanometrics.ca for more information.

1.2.1 Primary Media

TitanSMA continuously digitizes and records sensor data, measures and records state-of-health (SOH) data, and records configuration and log data in a proprietary database called the Store. The Store wraps when it is full and records over the oldest data. The frequency with which the Store wraps is shown in the [Internal Storage section](#) of the **Health Page**.

The Store is located on an internal flash media device which has standard capacity of 8 GB. This is expandable up to 64 GB in TSMA3– or later models.

Data is recorded to the Store in Nanometrics Protocol (NP) format, but digitized sensor data can be [streamed in SEEDLink](#) and NP formats for networked deployments, and/or archived to removable

¹Light-Emitting Diode

²Peak Ground Acceleration

media in [MiniSEED format](#). In addition, selected SOH channels are available in [Steim compressed formats](#). For networked deployments using continuous streaming, the Store is used to back fill any data lost during transmission downstream.

Regardless of whether you deploy TitanSMA as a networked or standalone device, the internal storage acts as your primary media. You can [retrieve data from internal storage](#) from the **Maintenance** page.

1.2.2 Secondary (or Removable) Media

The most effective backup for your data is to use an SD card as your secondary (removable) media, and configure continuous archiving. The SD card is formatted as FAT32.



To ensure reliability, we strongly recommend that you use only SD cards that are provided by or recommended by Nanometrics. Other types of cards may be unreliable, which may lead to loss of data.

The SD card serves two main functions:

1. Backup for the primary media for networked or standalone deployments.
2. Convenient data retrieval for standalone deployments.

When you enable continuous archiving, the TitanSMA continuously records data in MiniSEED format to the SD card. You can also configure TitanSMA to archive [events](#) and [SOH data](#) to the SD card.

When the [SD card is full](#), the TitanSMA continues recording data to its internal storage media, but stops writing data to your SD card. Any configured streamers are unaffected when the SD card is full. You can monitor the amount of space that data archiving consumes on your SD card from the [Removable Media](#) section of the **Maintenance** page.

For standalone deployments, swapping out removable media is a more convenient way of harvesting data than downloading data from internal storage using a laptop and Ethernet cable. Data retrieval via SD card swap or internal storage download is referred to as [file transfer](#).

1.3 Cables and Accessories

Nanometrics offers optional equipment that can add convenience to the installation and use of your TitanSMA. The table below describes a number of these options.

Name	Part Number	Description
Cable - Ethernet	15228-xM	<p>An Ethernet cable with a 4-pin, shell size 8 MIL-C-26482G Series 1 connector on one end and an RJ-45 connector on the other end.</p> <p>Available in standard lengths of 1 m, 2 m, 3 m, 5 m, 10 m, 15 m, 20 m, 30 m, 50 m, and 100 m. In the part number, xM represents the length of the cable in metres.</p>
Cable - Power	14983-xM	<p>An unshielded 22 AWG power cable.</p> <p>Available in standard lengths of 3 m, 5 m, 6 m, 8 m, and 10 m. In the part number, xM represents the length of the cable in metres.</p>
GNSS antenna cable LMR-400 low loss	12785-xM	<p>LMR-400 very low loss RF coaxial cable.</p> <p>Available in standard lengths of 25 m and 50 m. In the part number, xM represents the length of the cable in metres.</p>
GNSS antenna cable RG-223 low loss	12030-xM	<p>RG-223 low loss RF coaxial cable.</p> <p>Available in standard lengths of 10 m, 15 m, 20 m, 25 m, and 30 m. In the part number, xM represents the length of the cable in metres.</p>
GPS bullet antenna	15699	<p>A 3.3 V thread-mount GPS bullet antenna with a TNC connector.</p>
GPS patch antenna	15808	<p>A 3.3 V GPS patch antenna with a 5 m cable.</p> <p>Shipped with TitanSMA.</p>

Name	Part Number	Description
GPS cap	CON0278	Dust cap for GNSS connector port. NOTE: This optional accessory is required if a local GPS antenna is not being used.
Power supply	17236	Power supply with mains to 24 VDC. FOR INDOOR USE ONLY.
*SD Media Card	18023-xxGB	Secure Digital Media Card, Industrial Multi-level cell (MLC), pre-formatted with FAT32. Available in 16GB, 32GB, and 64GB capacities. In the part number, xxGB represents the storage capacity of the SD card.

*See [About SD media cards](#).

2.0 Installation Tasks

The TitanSMA is for anchored or freestanding installations. At a high level, we recommend that you perform the following tasks to install a TitanSMA:

- [Before field deployment \(pre-installation\)](#)
 1. Insert an SD media card (optional)
 2. Choose a deployment option.
 3. Perform the initial configuration.
 4. Develop a grounding plan.
- [In the field \(installation\)](#)
 1. Evaluate the installation site.
 2. Prepare the installation surface.
 3. Connect, place, and ground the device.
 4. Orient, level, and anchor (anchored installations only) the device.
- [Before leaving the installation site \(post-installation\)](#)
 - Monitor the LEDs and troubleshoot any errors that occur.
 - Record station information.

2.1 Before You Visit the Installation Site

Some planning and configuration tasks should be completed prior to deploying the TitanSMA in the field, specifically:

- Ensuring that your deployment has sufficient power supply.
- Choosing a deployment and data access option.
- Setting up the TitanSMA in a clean office or lab environment with network connectivity to perform pre-installation setup and configuration tasks.

2.2 Choose a Deployment Option

The TitanSMA can be deployed as a stand-alone device to record continuous data on removable media for extended periods of time or as a network device that allows data downloads, data streaming, and remote configuration changes while also recording data to the storage media.

Regardless of whether data is streamed and/or archived to removable media (an installed SD card), the TitanSMA continuously records data to internal storage. For more information, see [About Data Storage](#).

2.2.1 Stand-alone Deployment

In a stand-alone deployment, a TitanSMA is deployed as a “do-it-all” device. The recorded time series data is written in MiniSEED format to a FAT32 formatted SD card and written in NP format to the Primary internal storage flash memory storage and is recorded to the hot-swappable SD card, if an SD card is installed and if continuous archiving is configured by the user.

A technician must visit the TitanSMA in the field to retrieve the data, which is done by retrieving the removable media and replacing it with a new empty SD media card or by [downloading data from the internal storage](#).



Downloading data from the Primary Internal Store is a slow operation and is generally done either for small amounts of data or when the swappable SD card has been lost or damaged.

2.2.2 Networked Deployment

In a networked deployment, a TitanSMA is deployed as part of a network and the recorded time series data is written in NP format to the internal storage and also streamed over the network to a

data acquisition server, such as Apollo Server, using either the SeedLink or NP streaming protocol. As an additional backup, the TitanSMA can be configured to continuously write the time series data in MiniSEED format to a FAT32 formatted swappable SD card. See [Format SD Card](#).

The field technician does not typically visit the TitanSMA in the field after it has been installed, but instead uses a Web browser to make any necessary configuration changes and receive the streamed data.

2.2.3 Data Access Options

Typically, the data access method you choose is influenced by the remoteness and duration of the deployment.

The TitanSMA can be deployed as a:

- Network device that allows data downloads, continuous streaming to a data acquisition server (such as Apollo Server), and remote configuration changes.
- Stand-alone device to record continuous data on removable media for extended periods of time (accessed later via file transfer or retrieving the SD card when a technician is visiting the site).

Regardless of whether data is streamed and/or archived to a secondary removable media (SD card), the TitanSMA continuously records data to internal storage. For more information, see [About Data Storage](#).

Continuous Streaming

Continuous data streaming is usually the preferred data access method for longer term deployments.

Continuous data streaming uses the Ethernet port communicating through a hard-wired network, or wireless options such as a cellular modem, Low Earth Orbit (LEO) modem, or VSAT communication system, such as Nanometrics' Libra II VSAT System.

File Transfer

File transfer is more common for short-to-medium term deployments when streaming is not possible or practical. You can [remove the SD card](#) from the media bay and swap in a new SD card within one hour without causing any data gaps between the records on the two cards.

Alternatively, you can connect to the TitanSMA via Ethernet to download the data stored in its internal flash memory.

Data Formats

Each data access method provides specific data recording formats.

For a list of available data formats you can use for file transfer from SD card or internal storage, see [Data Recording and Retrieval](#) in the specifications.

To view the data formats available for data streaming, see [Data Products](#) in the specifications.

2.2.4 Use Cases: Deployment and Data Access

The table below illustrates the typical use cases for deployment and data access.

Deployment timeframe	Continuous data streaming required?	Data access option
Short-term (Temporary)	Yes	Streaming, using: <ul style="list-style-type: none"> • Wired Internet, cellular or satellite
	No	File transfer: <ul style="list-style-type: none"> • Removable media (SD card) • Internal storage via Ethernet (retrieve unit and bring to lab)
Medium-term (Semi-permanent)	Yes	Streaming, using: <ul style="list-style-type: none"> • Wired Internet, cellular or satellite
	No	File transfer: <ul style="list-style-type: none"> • Removable media (SD card)
Long-term (Permanent)	* Yes	Streaming, using: <ul style="list-style-type: none"> • Wired Internet, cellular or satellite

* Streaming is normally required for permanent stations because file transfer is often impractical.

2.3 Develop a Grounding Plan

The power consumption of the TitanSMA varies with factors such as the GNSS receiver duty cycle and the activity of the Ethernet. Typical consumption is listed in the [Power](#) section of the technical specifications.

The most appropriate grounding plan will depend on your application and the installation environment. Following is some general information you can take into account when planning grounding for a TitanSMA installation.

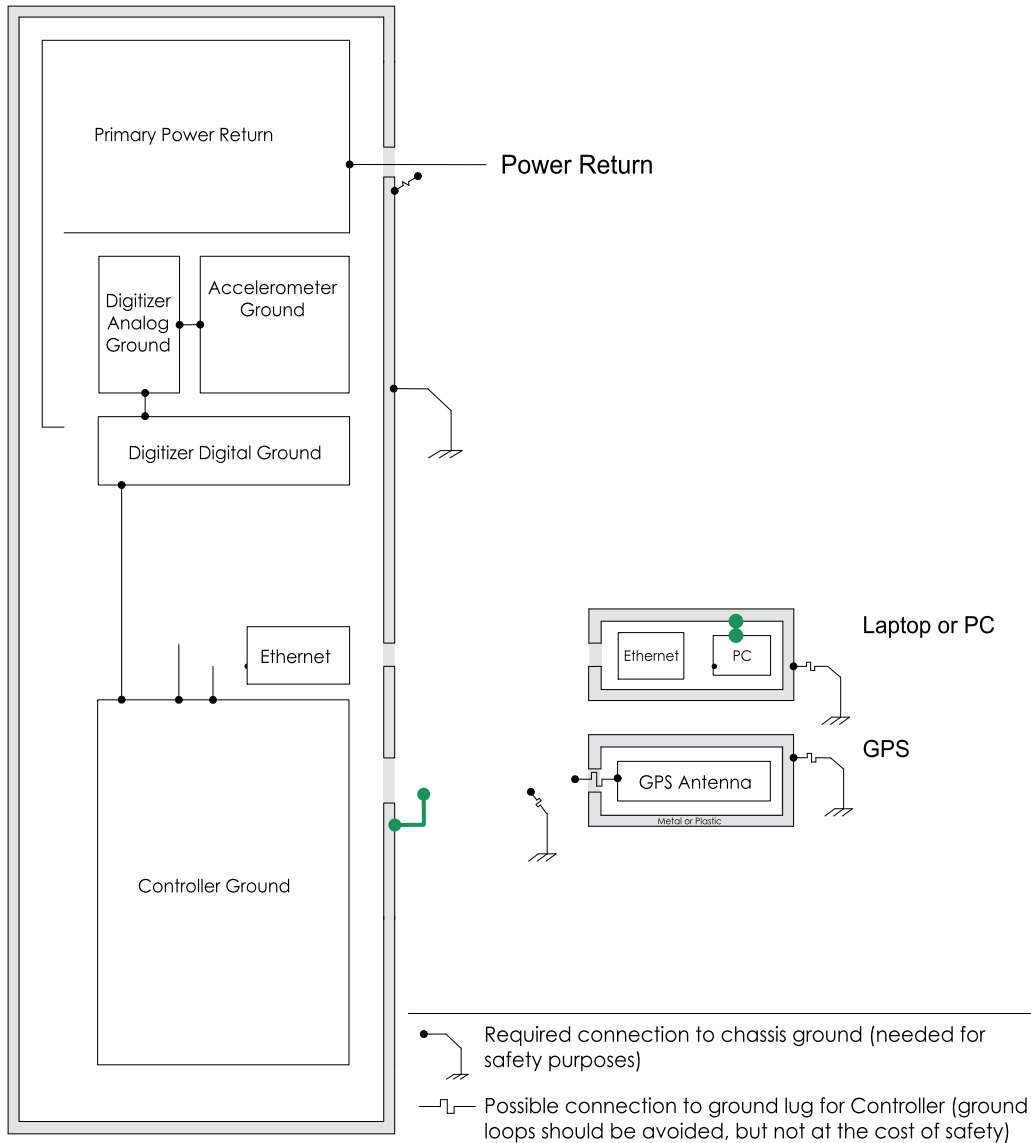

Primary power return is completely isolated from chassis, analog, and digital ground. Chassis (case) ground is connected to the analog ground of the digital recorder subsystem.



For the purpose of safety, the TitanSMA system chassis ground must be earthed. In most installations, for optimal performance, this should be done at one of the four grounding locations on the chassis, as shown in the following figure.

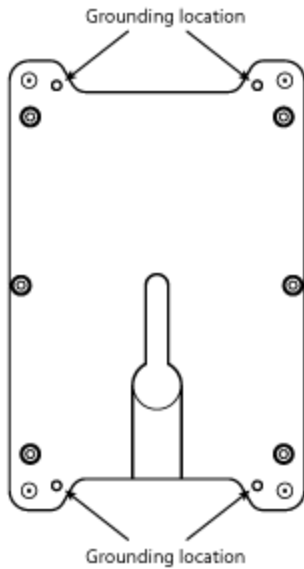

2.3.1 Power

The TitanSMA power connector has 3 pins to allow the instrument to conform to the site grounding system. You can connect the power return pin and ground but combining grounding and power return in the same conductor limits the site grounding options. The recommended practice is to establish a single ground point for the station and ground everything to that point, which minimizes the chances of ground loops and signal noise created by the power system.

2.3.2 GNSS Antenna

The GNSS antenna is referenced to digital ground which has a single point connection inside the TitanSMA to analog ground which is in turned connected to TitanSMA chassis ground. If the TitanSMA or attached sensor is grounded to earth, avoid making a second connection to earth ground at the GNSS antenna. If this is unavoidable, route the cables to minimize the area of the loop formed by the earth grounds and cables, as this loop behaves as an antenna to pick up noise and surge energy. If the TitanSMA and attached sensor are not otherwise grounded to Earth, connect the GNSS antenna to earth ground if possible.

In configurations that have long GNSS cables and lightning protection, an overall system design approach must be taken which balances the grounding requirements with the protection requirements. This approach requires an understanding of the TitanSMA grounding, the sensor grounding, power supply grounding, and local site grounding.

2.4 About SD Media Cards

Nanometrics tests with industrial-quality SD cards that have proven to be very reliable. [SD cards](#) are available in 16 GB, 32 GB, and 64 GB capacities. If you prefer to supply your own SD cards, please contact technical support for information about SD cards that have been qualified by Nanometrics.



To ensure reliability, we strongly recommend that you use only SD cards that are provided by or recommended by Nanometrics. Other types of cards may be unreliable, which may lead to loss of data.

2.4.1 Insert SD Card

The TitanSMA can be configured to archive MiniSEED data, event data, and SOH data to an **SD¹** card formatted as FAT32. The event data can be archived in multiple industry-standard formats.

Before data archiving can be enabled, an SD card (formatted as FAT32) should be inserted into the media slot on the behind the [media bay door](#) of the TitanSMA . When properly inserted and ready for use, the [Media LED](#) will blink green and the [Media Eject LED](#) behind the media door will be solid red for 10 minutes (it will then turn off to save power). See [Continuous Data Archive](#) and [Events Data Archive](#) for instructions on enabling data archiving on the SD card.

2.4.2 Remove or Swap the SD Card

Remove the SD Card

To safely remove the SD card, push and release the **Media Eject** button in the media bay, or click the **Eject** button in the **Removable Media** section on the Web Interface **Maintenance** page. Wait for the Media Eject LED to turn solid green, which indicates that it is safe to remove the. This should take less than 15 seconds.



To prevent data loss or corruption, the SD card should never be physically removed while the Media Eject LED is blinking in any colour.

¹Secure Digital



To prevent data gaps, insert the new SD card within one hour of removing the old one. After an SD card is removed, and before the new one is inserted, the Centaur continues to digitize and buffers data internally. When the new card is inserted, that buffered data is written to the SD card to achieve a continuous gap-free recording.

2.4.3 SD Card Full or Corrupt

The status of the SD card in use is indicated by the [Media LED](#) on the instrument, and on these Web Interface pages:

- [Health > Storage section](#)
- [Maintenance > Removable Media section](#)

If your SD card is full or corrupt, the instrument continues recording data to its [Store](#), but stops writing data to your SD card. Any configured streamers are unaffected when the SD card is full or corrupt.

SD Card Troubleshooting

- The most effective way to retrieve data directly from the TitanSMA's **internal storage**¹ is by downloading it from the **Maintenance** page to your computer.
- To ensure sufficient space on your SD card, you can remove older time series data from your [continuous archive](#). The safest method for transferring data from the SD card is to connect it to your computer. Alternatively, you can use secure FTP and the client application of your choice to manage your continuous archive files.
- Individual archive files can also be downloaded from the [Download archive files](#) link from the **Maintenance** page.
- If your SD card is corrupt or damaged, you can try to repair it from the Maintenance page. You may also re-format the card. Repair and re-formatting of SD cards is performed in the [Removable Media section](#) of the **Maintenance** page.

¹The device writes all of the data it receives to its Primary Internal Storage. The internal storage works like a ring buffer and it wraps around when it is full and records over the oldest data.

2.5 Perform the Initial Configuration

Each TitanSMA comes factory-configured with several default configuration settings. The factory configuration addresses the most common use cases for the TitanSMA and means that most devices will require minimal pre-installation configuration.

To check the configuration, you must connect the GNSS, Ethernet, and power cables and wait for the device to power up. Once started, you need to [access the Web interface](#) of the TitanSMA to verify or change the configuration.

You should ensure the following settings are [configured](#) to your needs prior to deploying the device in the field:

- [Sample rate](#)
- [Detector settings](#)
- [Ethernet settings](#)
- [Streamer settings](#) (Networked deployment)
- [Timing source settings](#)
- [Archiving to SD card](#)

2.6 Perform a Tilt Test

A tilt test is an effective way to become familiar with the TitanSMA and how it records motion. The test involves holding the TitanSMA and rotating it while watching the **Mean** value for each channel in real-time on the [Waveform](#) page.



To avoid clipping, the device should be in 2 g or 4 g [mode](#) when performing a tilt test.

2.7 Evaluate the Installation Site

When deciding where to install a TitanSMA, it is important to understand the expected range of motion at the site, ensure that the GNSS antenna will have a clear view of the sky, and to evaluate the available installation surfaces.

To achieve accurate measurements, it is recommended that you [anchor](#) each TitanSMA to a hard, unyielding surface, such as concrete, masonry, or metal, that is flat, level, and free of debris and obstacles. Anchoring the device to the installation surface is recommended because ground motion can cause an unsecured TitanSMA to shift and produce inaccurate measurements. Each TitanSMA is

shipped with the necessary hardware to secure the devices to concrete, masonry, or metal surfaces.

Where less than 0.1 g of motion is expected, a TitanSMA can be placed [freestanding](#) on the installation surface. As with anchored installations, the installation surface for a freestanding TitanSMA should be flat, level, and free of debris and obstacles.

Next, ensure that there is a suitable location for mounting the GNSS antenna. The antenna must have a clear view of the sky and be within an acceptable distance for connecting the cable to the TitanSMA.

Finally, consider how the device will be oriented. Options include orienting the TitanSMA with the directions of the compass (north-south or east-west) or aligning it with the primary axis of the structure where it is being installed.

The table below shows the approximate values that you should see for each channel in various orientations.

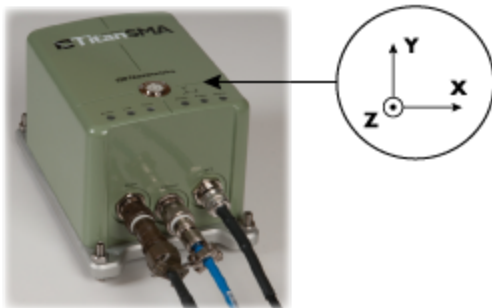

Orientation	X (g)	Y (g)	Z (g)
X and Y arrows horizontal (device on its feet)	0	0	0
X arrow up (device on left side)	+1	0	-1
X arrow down (device on right side)	-1	0	-1
Y arrow down (device resting on media bay door)	0	-1	-1

2.8 What You Need for an Anchored Installation

You will need the following to properly orient, anchor, and level a TitanSMA on a concrete, masonry, or metal surface:

Item	Supplied by	Usage
Compass	Installer	To orient the TitanSMA to north-south or east-west
Drawing tools	Installer	To mark the installation surface
Hardware (anchor or bolt)	Nanometrics (included in the TitanSMA installation kit)	<p>For concrete or masonry surfaces</p> <ul style="list-style-type: none"> ○ One 1/4 in. masonry sleeve anchor bolt (complete with the washer and blue sleeve) with 11/64 in. head height <p>For metal surfaces</p> <ul style="list-style-type: none"> ○ One M6x25 hex bolt with M6 hex nut
3 mm hex screwdriver	Nanometrics (included in the TitanSMA installation kit)	For locking the levelling screws
Adjustable wrench or 10 mm wrench	Installer	For locking the levelling screws
Cables	Installer / Nanometrics	<p>For part numbers and descriptions of cable options, see TitanSMA Optional Equipment.</p> <p>See Connectors and Pinouts for connector pinout tables and diagrams.</p>
GPS patch antenna	Nanometrics	For timing purposes

Item	Supplied by	Usage
Grounding wire	Installer	To connect the TitanSMA to the site ground <ul style="list-style-type: none"> ○ 10 AWG is recommended. ○ Cut the cable to length to remove excess and minimize voltage drop.
Grounding lug, M4	Installer	To ground the TitanSMA <ul style="list-style-type: none"> ○ The grounding lug must accommodate the gauge of the grounding wire used.
M4x5 screw and M4 washer	Nanometrics (included in the TitanSMA installation kit)	To attach the grounding lug to the TitanSMA

2.8.1 Prepare the Installation Surface

Perform the following steps to prepare the installation surface for installing and orienting the TitanSMA:

1. Select an installation location that is flat and level and ensure that it is clean and free of obstacles.
2. Determine the desired orientation of the TitanSMA, such as aligned with true north or in line with the primary axis of the structure.
3. If using a directional orientation, use the compass and drawing tools to draw a line on the concrete parallel to the selected orientation direction. If you are using a magnetic compass, account for the local magnetic declination when drawing the line.

-OR-

If aligning the TitanSMA along the primary axis of the structure, draw a line parallel to this axis.

4. Indicate the drilling location by marking the desired location on the orientation line.

When adding this mark, ensure that there is a buffer of 20 cm around it that is free of obstacles and debris. The mark represents the centre point of the TitanSMA and is the location where the anchor or bolt that will hold the TitanSMA in place will be set into the surface.

2.8.2 Drilling Guidelines

The following figures provide suggested drilling guidelines for hardware supplied by Nanometrics.

Concrete or masonry surface

Hardware: 1/4 in. masonry sleeve anchor bolt (Make sure to use the flat washer that is included with the anchor bolt.)

Drill bit: 1/4 in. concrete drill bit

Hole depth: 40 mm (1.5 in)

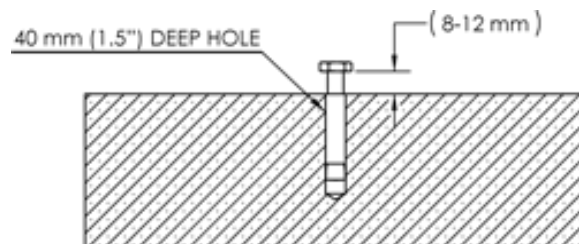

Metal surface, tapped hole

Hardware: M6x25 hex bolt

Drill bit: drill and tap for M6 thread

Hole depth: 20 mm drilled and tapped for M6 thread

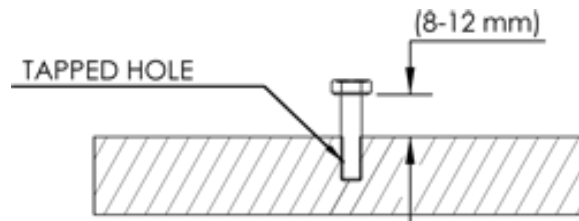

Metal surface, through hole

Hardware: M6x25 hex bolt

Drill bit: 6.5 mm or as desired for M6 clearance hole

Hole depth: through hole

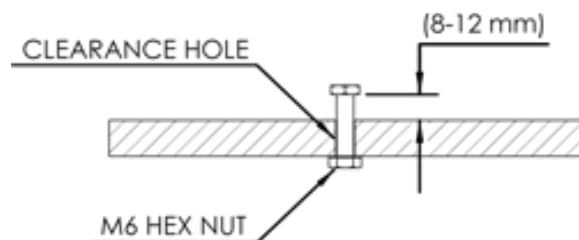

2.8.3 Install and Anchor the TitanSMA

Perform the following steps to install and anchor a TitanSMA:

1. Mount the GNSS antenna so that it has a clear view of the sky.
2. Ensure the length of each cable is sufficient to
 - Connect to the accelerograph and its destination point (for example, the destination point for the power cable is the power source)
 - Allow for strain relief
3. Connect each cable to the TitanSMA but not to its destination point.
4. Select the [anchor or bolt](#) you will use to attach the TitanSMA to the installation surface.
5. Drill a hole at the [drilling location marked on the installation surface](#).

Use an appropriate drill bit for the surface type and the selected anchor or bolt. For more information, see [Drilling Guidelines](#).

6. Clear **all** debris from the hole.
7. Insert the selected bolt into the hole. Ensure that the bottom of the bolt head is 8 mm to 12 mm above the surface.



For masonry or concrete installations, ensure that the sleeve of the anchor bolt is flush with the installation surface. For more information, see the image for the sleeve anchor bolt in concrete or masonry in [Drilling Guidelines](#).

8. Using the guide in the bottom of the TitanSMA, fit the TitanSMA over the head of the anchor or bolt.

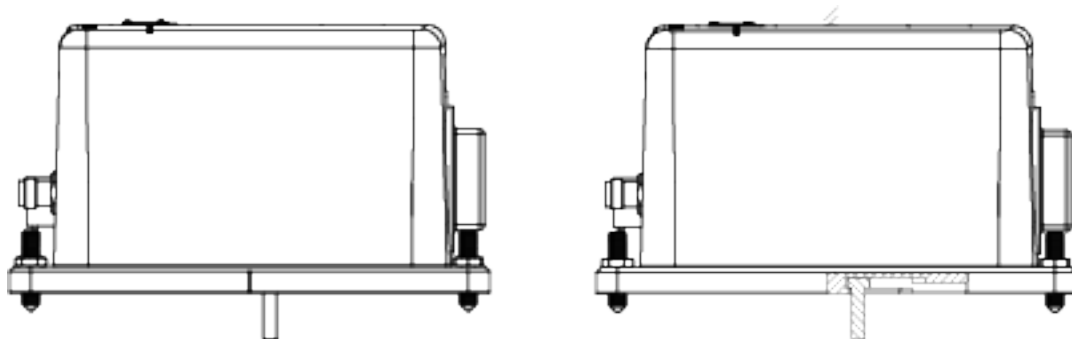

The images above show how the slot in the back of the TitanSMA fits over the head of the anchor or bolt set into the installation surface. For a full view of the back of the TitanSMA, see "Bottom View" on page 163.

9. [Ground](#) the TitanSMA using the following steps:
 - i. Strip one end of the grounding wire and crimp the grounding lug around the grounding wire.
 - ii. Attach the grounding lug to the grounding hole using the M4x5 screw and the M4 washer.
 - iii. Connect the other end of the grounding wire to a grounding point at the site.
10. To orient the TitanSMA, turn it so that its X directional marker is aligned with the [line drawn on the installation surface](#).
11. Adjust the levelling screws until
 - o The levelling bubble is in the centre of the black ring.
 - o The levelling screws are extended to the maximum extent permitted by the anchor or bolt. As the levelling screws are turned into the surface, the TitanSMA is lifted away from it, creating a secure connection between the TitanSMA and the head of the anchor or bolt.



For installations on concrete or masonry surfaces, over-tightening the levelling screws may pull the anchor or bolt out of the installation surface.

12. Lock each of the levelling screws by inserting the 3 mm hex screwdriver into the screw to stop it from rotating and using a wrench to firmly tighten the lock nut.
13. Strain relieve each of the cables to the installation surface.



Tie-wraps with tie-wrap anchors or a heavy object are effective tools for achieving strain relief.

14. Connect each cable to its destination point and make sure that the cable runs from the strain relief to the TitanSMA are not under tension, kinked, or in compression.



When you connect the power cable to the power source, the TitanSMA will power up immediately. It will take approximately 2 to 3 minutes for the device to completely start up.

If the device fails to power up, the power supply voltage might be below the configured [Voltage reconnect](#) threshold. For more information, see [Troubleshooting Your Installation](#).

15. Ensure that the levelling bubble is still indicating that the device is level. If the device is not level, level it again.

2.9 What You Need for a Freestanding Installation

For lab testing or at sites where less than 0.1 g of motion is expected, a TitanSMA can be placed freestanding on the installation surface. The installation surface for a freestanding TitanSMA should be flat, level, and free of debris and obstacles.



To achieve accurate measurements, it is recommended that you anchor each TitanSMA to a hard, unyielding surface, such as concrete, masonry, or metal, that is flat, level, and free of debris and obstacles (see also [Install and Anchor a TitanSMA](#)).

When setting up a freestanding TitanSMA, you will use the fixed foot that is supplied with each TitanSMA to create a 3-foot installation that can be made level without securing the device to the installation surface.

You will need the following to create a levelled and aligned freestanding installation of one or more TitanSMAs:

Item	Supplied by	Usage
Straightedge or equivalent	Installer	For alignment when setting up multiple devices.
Fixed foot	Nanometrics (included in the TitanSMA installation kit)	To act as a third foot for accurate levelling in installations where the device is not anchored to the installation surface.

Item	Supplied by	Usage
3 mm hex screw-driver	Nanometrics (included in the TitanSMA installation kit)	For removing and replacing the screw in the base For locking the levelling screws
Adjustable wrench or 10 mm wrench	Installer	For tightening the fixed foot For locking the levelling screws
Cables	Installer / Nanometrics	For part numbers and descriptions of cable options, see TitanSMA Optional Equipment . See Connectors and Pinouts for connector pinout tables and diagrams.
GPS patch antenna	Nanometrics	For timing purposes

2.9.1 Install a Freestanding TitanSMA

Use the following figure as a reference when installing a freestanding TitanSMA:

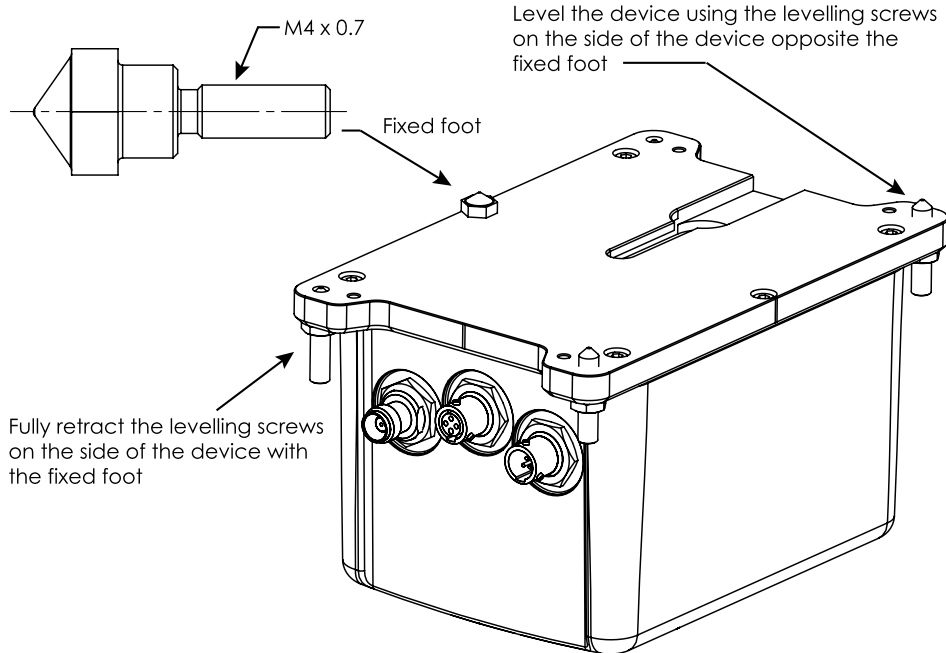
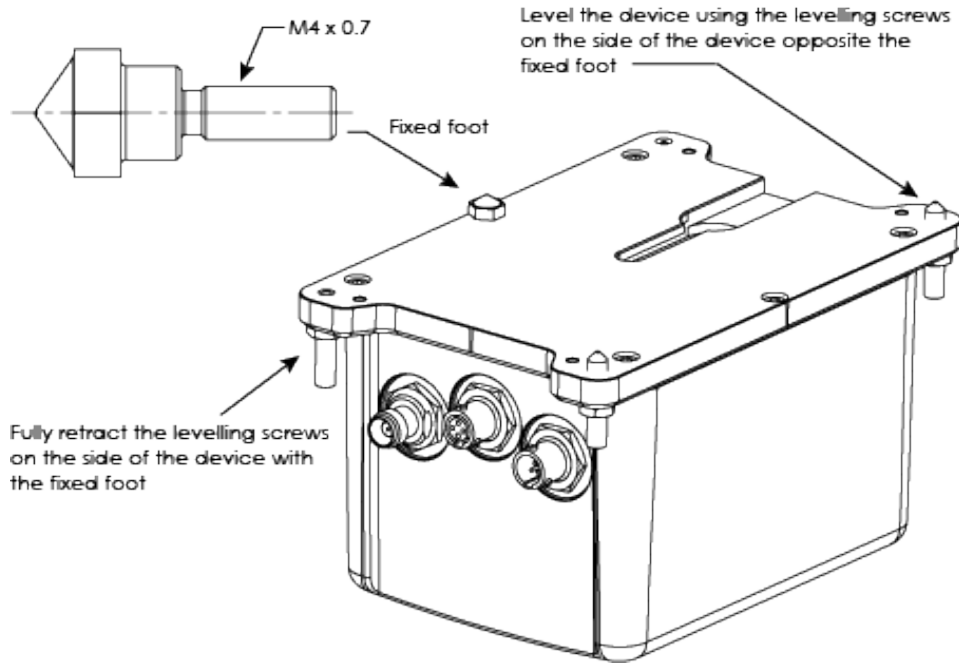

Perform the following steps to perform a freestanding installation of one or more TitanSMAs:

1. Select an installation surface that is flat and level and ensure that it is clean and free of obstacles.
2. Ensure the length of each cable is sufficient to
 - Connect to the TitanSMA and its destination point (for example, the destination point for the power cable is the power source)
 - Allow for strain relief
3. If you are setting up more than one device, place the straightedge (or equivalent, such as a line drawn on the installation surface) on your installation surface.



If you are only setting up one TitanSMA, the orientation of the device does not matter. However, if you are setting up multiple devices, you should align all devices to the same reference point for data comparison purposes.

4. Mount the GNSS antenna(s), ensuring a clear view of the sky.
5. For each TitanSMA you are setting up
 - a. Use the 3 mm hex screwdriver to remove one of the middle screws from the base plate of the TitanSMA. Retain the screw.

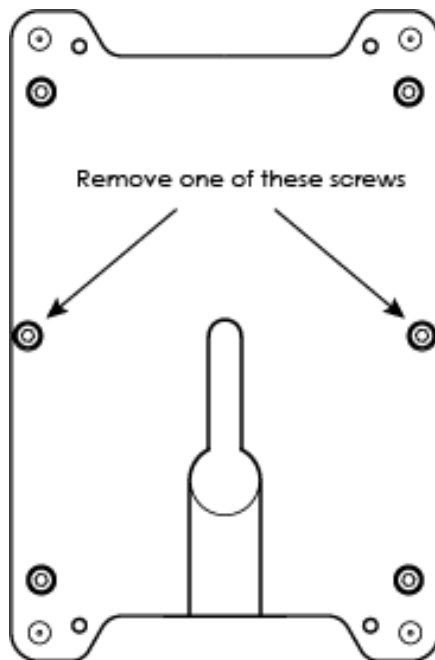

When the freestanding installation is no longer needed, replace the screw in the base plate and tighten it to 22 in-lb.

- b. Insert the fixed foot into the empty screw hole and torque to 22 in-lb.

- c. Fully retract, but do not remove, the levelling screws on the side of the device where you installed the fixed foot.
- d. If there are multiple devices, align each with the orientation line on the surface.
- e. Connect each cable to the TitanSMA but not to its destination point.
- f. Adjust the two levelling screws on the side opposite the fixed foot until the levelling bubble is in the centre of the black ring.
- g. Lock the levelling screws so the device remains level by inserting the 3 mm hex screwdriver into one of the screws to stop it from rotating and using a wrench to firmly tighten the lock nut.
- h. Strain relieve each cable to the installation surface.



Tie-wraps with tie-wrap anchors or a heavy object are effective tools for achieving strain relief.

- i. Connect each cable to its destination point and make sure that each cable run from the strain relief to the TitanSMA is not under tension, kinked, or in compression.



When you connect the power cable to the power source, the TitanSMA will power up immediately. It will take approximately 2 to 3 minutes for the device to completely start up.

If the device fails to power up, the power supply voltage might be below the configured [Voltage reconnect](#) threshold. For more information, see [Troubleshooting Your Installation](#).

- j. Ensure that the levelling bubble is still indicating that the device is level. If the device is not level, level it again.

2.10 Post-installation Activities

At the installation site, these are activities you might want to perform:

- o [Monitor the LEDs](#) for flashing red lights
- o Verify your installation steps against the [installation checklist](#)
- o Record the [station information](#)
- o [Troubleshoot](#), if necessary

After your installation is complete, you can [access the Web interface](#) to monitor the status and health of your TitanSMA remotely. You can quickly check the health of the device from any page by looking at the status bar at the top of the page.

2.10.1 Troubleshooting the Installation

To troubleshoot your installation, first ensure that you have completed the [Installation Checklist](#).

Following are some problems that might occur in a TitanSMA installation with possible causes and solutions.

Spikes on the Horizontal Channels

The feet of the TitanSMA are not locked or properly tensioned against the anchor bolt.

There is something touching the sides of the TitanSMA.

Continuous Low Frequency Drift (Random or Periodic)

The TitanSMA is exposed to air drafts or large temperature changes. Install an insulating cover over the device.

Spikes on All Channels Simultaneously

Usually due to electrical system noise. For example, power supply noise from a battery charging circuit, or interference from a strong magnetic or radio source that is nearby.

Drift on Startup

A small amount of drift is normal as the TitanSMA is coming to equilibrium temperature. It should stabilize within 1 hour.

Does not Power On

The power supply voltage might be below the configured [Voltage reconnect](#) threshold. If the power supply voltage is below the configured threshold, the device will not power up.

To fix this problem, you can connect a power supply that is above the configured threshold or you can force the device to power up by pressing and holding the **Force Power On** button behind the media bay door until the [Power LED](#) turns on.

2.10.2 TitanSMA Installation Checklist

Use the following checklist to help you verify that you have completed all of the necessary steps in the installation of your TitanSMA.

- Installation surface is clear of debris.
- TitanSMA N direction is aligned to true north (accounting for the magnetic declination).
- TitanSMA is level.
- Levelling screws are extended and tensioned against the anchor bolt.
- Levelling screws are locked.
- Serial number is noted.
- Required cables are connected.
- GPS antenna is attached.
- Cables are strain-relieved to the installation surface.
- Cables are not touching the TitanSMA case.
- X, Y, and Z channels are zeroed using the channel offset feature.
- SD card is installed (optional) and the media bay cover is closed.
- Power is on.
- [Configuration](#) is complete.
- The Status LED is blinking green and none of the values on the [Health](#) page are red (for more information, see [Monitoring the LEDs](#)).
- Ensure that seismic waveforms are displayed on the [Waveform](#) page.

2.10.3 Station and Device Information

Use the following table to record information about the installation and station. This information will be helpful in identifying changes to the station over time.

Station Information	
Station code:	
Network code:	
Station address:	
Latitude-Longitude-Elevation:	
Station contact:	
Check-in with:	
Business hours:	
Directions:	
Keys needed:	Yes/No
Parking:	
Date of installation:	
Installation surface type:	
Secured to surface:	Yes/No

Description of installation site:	
Device Information	
Device type:	
Device location at site:	
Device serial number:	
Device IP address:	
Expected range of motion:	_____ g to _____ g
Device orientation:	Orientation of Z arrow _____ Orientation of Y arrow _____ Orientation of X arrow _____
Keys needed:	Yes/No
Device history:	
Inspection dates:	
Notes:	

3.0 Accessing the Web Interface

The Web Interface is where you can assess the status and health of your instrument, configure your sensor, view the waveform, and perform maintenance tasks, such as backing up your configuration settings and upgrading your firmware.

You can create a [direct connection](#) to your TitanSMA using a link-local IP address or you can create a [network connection](#) to the device.

3.1 The Summary page

When you first log on to the Web Interface for your TitanSMA the **Summary** page is displayed. Using a series of coloured status bars and status indicators, this page provides an at-a-glance view of the key device status information relating to the timing, media, configuration and simplified waveforms allowing you to easily monitor the device during installation.

The **Time** section provides a high-level view of the status of the internal system clock, and an estimate of the clock's timing uncertainty. If GNSS timing is configured, this section also provides the number of GNSS satellites used by the GNSS receiver for position calculation. You can also view this information in more detail from the [Time](#) section on the **Health** page.

The **Media** section quickly tells you whether an archive SD media card is installed, the last time that the archive was written to and the size of the Internal Storage in the seismometer. You can view more detailed information about the media from the [Storage](#) section on the **Health** page.

The **System** section indicates if the configuration has been committed. It also indicates the file name of the last configuration file uploaded to the device. A blank value indicates that no configuration has been uploaded. You can view detailed information about the configuration from the [Firmware](#) section of the **Maintenance** page.

Waveforms on the Summary page

As mentioned earlier, the **Summary** page also provides simplified waveforms allowing you to easily monitor the device during installation. Navigating to the [Waveforms](#) page gives you a more detailed view of these waveforms.

To ensure that waveforms are displayed correctly, make sure that you have installed one of the following browsers: Chrome version 16 or newer, Firefox version 11 or newer, or Safari version 7 or newer.



If you attempt to view waveforms on more than two Web Interfaces at the same time, the error message "An error occurred receiving waveform data" will be displayed.

3.2 Direct Connection to the Web Interface

For a direct connection between your instrument and a computer (with Chrome, Firefox or Safari installed), use the link-local IP address 169.254.30.30.

3.3 Network Connection to the Web Interface

1. Connect the TitanSMA to a DHCP-enabled network and allow it to automatically assign an IP address to the device.
2. Use Apollo Discovery, a Nanometrics application, to search the LAN for Nanometrics instruments and applications.



Contact Nanometrics Support at <http://support.nanometrics.ca> to get Apollo Discovery.

Apollo Discovery must be run on the same subnet as the devices you want to find.

3. Confirm that the serial number displayed on the Web interface matches your TitanSMA. If it does not, then you are connected to a different TitanSMA in your network.



After connecting to the TitanSMA, either through the link-local address or via a DHCP-enabled network, you can configure a static IP address for your deployment.

3.4 Logging on to the TitanSMA Web Interface

When you first connect to the Web Interface, you are in view only mode. This mode allows you to view information about your instrument such as the status and health of your instrument, the connected sensors, events and waveforms. To edit the configuration, upload firmware, and perform maintenance tasks, you need to log on to your Web Interface.

1. From the upper right corner of the Web Interface, click **Log On**. The Log On dialog box will be displayed.
2. Enter the current admin account username and password.
3. Click the **OK** button. On the Web Interface, **admin** will display in place of Log On.



To increase the security of your network and to significantly reduce the risk of unauthorized access to your TitanSMA, we recommend that you change all default passwords after you have logged on for the first time. See [About Passwords](#).

3.5 About Passwords

For Nanometrics instruments, password authentication is used for more than one interface. To increase the security of the instruments, it is important to ensure that all of these default passwords are changed. Follow the links below for details on how to change each type of password:

- [The root password is changed using an SSH client](#)
- [The calibration password is changed using an SSH client](#)
- [The admin password is changed from the Web Interface](#)

Before you begin, refer to the [guidelines for creating a strong password](#).

3.5.1 Guidelines for creating a strong password

You should change the default passwords for all interfaces prior to deploying the TitanSMA. A strong password should:

- be a minimum of 8 characters long
- include a combination of upper and lower case letters
- include numbers
- NOT be based on dictionary words

If you require more information, there are several resources available on the Internet to help with the choosing and generation of strong passwords.

3.5.2 Changing the root password

After successfully logging in to the TitanSMA using an SSH client such as PuTTY, you can run the `passwd` command to change the root user's password:

1. If you do not have an SSH client such as PuTTY, download one from the Internet.
2. Launch the SSH client and connect to the instrument using the instrument's IP address and default port number 22.

3. If the connection was successful, a login screen will open. Log in to the instrument as the root user using the current root username and password.



The factory defaults are username: **root**, password: **dolphin18**.



To increase the security of your network and to significantly reduce the risk of unauthorized access to your TitanSMA, we recommend that you change all default passwords after you have logged on for the first time. See [About Passwords](#).

4. To change the root password, at the prompt, run the following command:
passwd
5. Enter your new password. Passwords must be a minimum of characters 8 characters long and include a combination of upper and lower case letters and numbers. See [Guidelines for creating a strong password](#).
6. Reenter your new password.
7. If you have not changed the calibration password from the factory default values, continue to [step 4](#) in [Changing the Calibration Password](#).

3.5.3 Changing the Calibration Password

The calibration user account and password allows you to upload a custom calibration file to the instrument. See [Uploading a custom calibration signal file](#). You can change the calibration user password by logging in to the instrument as the root user using an SSH client such as PuTTY:



To increase the security of your network and to significantly reduce the risk of unauthorized access to your TitanSMA, we recommend that you change all default passwords after you have logged on for the first time. See [About Passwords](#).

1. If you do not have an SSH client such as PuTTY, download one from the Internet.
2. Launch the SSH client and connect to the instrument using the instrument's IP address and default port number 22.
3. If the connection was successful, a login screen will open. Log in to the instrument as the root user using the current root username and password.



The factory defaults for the root user are username: **root**, password: **dolphin18**.
The factory defaults for the calibration user are username: **calibration**, password: **calibrate**.

4. To change the calibration password, at the prompt, run the following command:
passwd calibration
5. Enter your new password. Passwords should be a minimum of 8 characters long and include a combination of upper and lower case letters and numbers. See [Guidelines for creating a strong password](#).
6. Reenter your new password.
7. Close the SSH session.

3.5.4 Changing the admin password



The factory defaults for the admin user are username: **admin**, password: **admin**.



To increase the security of your network and to significantly reduce the risk of unauthorized access to your TitanSMA, we recommend that you change all default passwords after you have logged on for the first time. See [About Passwords](#).

After successfully logging in to the instrument's Web Interface, you can change the user's password from the admin menu:

1. From the upper right corner of the Web Interface, click on **admin** and select **Change password** from the list. The change password dialog box will be displayed. Passwords must be between 8 and 10 characters long and include a combination of upper and lower case letters and numbers. See [Guidelines for creating a strong password](#).
2. Enter your **User name**, your **Old password**, and your **New password**.
3. Confirm your new password by entering it in the **Confirm new password** field.
4. Click the **OK** button. The dialog will close and your password will be set to the new password.

3.6 Configuring instrument security



WARNING: You can become locked out of the instrument if the firewall is configured incorrectly. Only people with advanced working knowledge of Linux should attempt to configure a firewall for Nanometrics instruments.

In addition to changing instrument passwords, you can improve instrument security by configuring a firewall for your network using the `iptables` firewall utility for Linux. This utility allows you

to specify sets of IP addresses, IP networks and subnetworks that can communicate with your Nanometrics instruments. You can also block IP addresses, IP networks and subnetworks from communicating with your Nanometrics instruments.

The TitanSMA includes a sample file for defining `iptables` rules and automatically applying them on startup. This file is located at `/etc/iptables.commands`. By default, the rules included in the file are disabled (commented out). You can edit this file to suit your specific needs, then reboot the TitanSMA to enable the functionality.

For guidance on configuring firewalls for Nanometrics instruments, please contact Nanometrics support at <http://support.nanometrics.ca/>. See <https://linux.die.net/man/8/iptables> and <http://www.iptables.info/en/iptables-contents.html> for further information on the `iptables` firewall utility.

4.0 Configuring Your TitanSMA

You can change the configuration settings for the TitanSMA by logging on using the admin user account, opening the Configuration menu, and selecting **Configuration**.



To increase the security of your network and to significantly reduce the risk of unauthorized access to your TitanSMA, we recommend that you change all default passwords after you have logged on for the first time. See [About Passwords](#).

Configuration menu icon



Reset, Apply, Commit

- **Reset** – Discard any unapplied changes and reload the current configuration settings.
- **Apply** – Implement changes before they are committed. The device will operate with the new settings but will discard them if it is restarted.
- **Commit** – Permanently save changes. The device will use these new configuration settings each time it restarts until new settings are committed.

4.1 Downloading/Uploading the Configuration



Nanometrics recommends that you only use configuration files created with the current firmware version. Use of configuration files from other firmware versions may cause unexpected behaviour.

You can download the current configuration of the TitanSMA and save it as a backup in case you ever want to restore the settings of the TitanSMA to the current state or upload it to a different TitanSMA. The downloaded configuration file is in RDF Turtle format (see <http://www.w3.org/TeamSubmission/turtle/>).

If you do upload a configuration file, keep in mind that you might have to use Apollo Discovery to find the new IP address assigned to the device if the [Ethernet mode](#) changes from Static IP or Link-Local to DHCP.

Apollo Discovery is a Nanometrics command-line application that searches the LAN and returns the model number, serial number, IP address, and other information about the Nanometrics devices and applications that it finds. You can download Apollo Discovery from our support Web site: <http://support.nanometrics.ca>.

4.2 General Configuration Settings

Configuration title

This option allows you to configure a name for the configuration on your device. This is especially useful if you have deployed a system where multiple devices share a configuration file. This value will appear on the Web interface Summary page.

When you upload a configuration file, and the Configuration title is not set in the uploaded configuration itself, the system will automatically set the Configuration title to the filename of the uploaded configuration file.

Before downloading the configuration to be shared with other devices, either enter a name in the Configuration title field or ensure that the field is empty so that the configuration filename will be entered in the field when the configuration is uploaded to the other devices in the system.

System log verbosity

The level of detail of the system log:

- Info - All errors, warnings, and minimal system status information
- Verbose - All error, warnings, and more detailed system status information
- Debug - All errors, warnings, and extensive system status information



You should only select **Verbose** or **Debug** as the logging level if you were instructed to do so by Nanometrics Technical Support because it generates a large number of log messages that can slow down the system and shorten the amount of time in the log files.

Retrieval mark

The date and time the last data was retrieved by Apollo Project for a Field Archive project.

Apollo Project automatically stores this date in the TitanSMA after it retrieves data for a Field Archive project and uses it as the starting point for a future data download. The Retrieval Mark box is blank if Apollo Project has not been used to download data from a TitanSMA for a Field Archive project.

You can delete the date if you want Apollo Project to download all of the data from the start of the project the next time you run a Field Archive project. You can also change the date if you only want data downloaded from a specific point in time.



This setting is only used by Apollo Project for Field Archive projects. If you do not use Apollo Project or Field Archive projects, you can ignore this setting. For more information on data retrieval and Field Archive projects, see the Apollo Project User Guide.

Libra compatibility streaming

Use this option to enable your TitanSMA to stream through a Libra satellite modem. By default this option is not selected.

To use this option, select the check box to enable the option, then configure the NP UDP Streaming [Throttle](#) settings.

4.3 Accelerometer

The TitanSMA has a force balance triaxial accelerometer with a low noise floor, exceptionally low hysteresis, and a wide dynamic range. You can configure the mode and the channel offset for the TitanSMA accelerometer.

Mode

Select the mode in g for the horizontal and vertical channels.

The mode specifies the full scale range and [sensitivity](#) of the accelerometer.

Channel offset n [g]

Enter the offset of the channel in g. You can view the mean value on the [Waveform](#) page.

4.4 Channel Naming

The channel names are used by the TitanSMA for two different purposes:

- Data Retrieval - The channel names are used in the file headings and default file names for all types of retrieved data. The names act as labels to help you identify the data. For more information, see [Retrieve Data from the Internal Storage](#).
- Filtered Streaming - When you configure the TitanSMA to stream data, you have the option to define an SCNL-based filter to limit what channels are streamed. The TitanSMA refers to the channel names when it performs the filtering.

TitanSMA retains only the currently configured channel name. Historical naming information is not preserved.

When you make a query to retrieve data or to view a waveform from TitanSMA, make sure to use the channel name that is currently configured, not the channel name that was configured when the data was recorded.

Network code

A two character alphanumeric code (the alpha characters must be uppercase) that represents the network that the TitanSMA belongs to.

Station code

A five character alphanumeric code that represents the station where the TitanSMA is located.

Location code

A two character alphanumeric code (the alpha characters must be uppercase) that represents the time series location of the TitanSMA. This value is superseded if a location code is explicitly included with a channel code.

This setting is optional.

Channel code (for Primary or Secondary sample rates)

A three character alphanumeric code (the alpha characters must be uppercase) that represents each of the primary and secondary data channels. Optionally, a two-character location code can be included before the channel code if a unique location code is required for each channel. (For example, 00.HHN where 00 is the location code and HHN is the channel code.) If the location code is specified with the channel code in this field, the value in the Location code field is overridden.

The two codes have to be separated by a dot (.).

SOH code

A two character alphanumeric code for the location and a three character alphanumeric code for the channel that represents the SOH for the TitanSMA.

The two codes have to be separated by a dot (.).

4.5 Communications

You can configure a TitanSMA for network access using an IP connection over an Ethernet connection.

4.5.1 Discovery

Enable discovery

Select this check box to allow the TitanSMA to periodically send out small multicast identification messages to other Nanometrics devices and applications on the network.

IP address

A valid multicast IP address.

Port number

The UDP port number used by the TitanSMA for discovery broadcasts.

4.5.2 Ethernet

Ethernet mode

The method that the TitanSMA uses to acquire an IP address for communications over the LAN.

By default, each TitanSMA ships in DHCP mode so it can automatically obtain an IP address in your network. If needed, you can also use the following Link-Local address: 169.254.30.30.

If you change this setting to another Ethernet mode (**Static IP** or **Link-Local**) and then change it back to **DHCP**, you can use Apollo Discovery to find the new IP address assigned to the device. You will need this new IP address to be able to commit the change you made to the Ethernet mode setting because the previous IP address will no longer work.

Apollo Discovery is a Nanometrics command-line application that searches the LAN and returns the model number, serial number, IP address, and other information about the Nanometrics devices and applications that it finds. Apollo Discovery is part of Apollo Toolkit, which ships with TitanSMA. The Apollo Toolkit User Guide contains instructions for installing and using Disco.

Static IP address

If the selected Ethernet mode is **Static IP**, enter the IP address to be assigned to the TitanSMA for the LAN.

Static subnet mask

If the selected Ethernet mode is **Static IP**, enter the subnet mask for the static IP address.

Static default gateway

If the selected Ethernet mode is **Static IP**, enter the default gateway address for the static IP address. If routing to remote networks is not required, this field may be left blank.

Primary DNS server

If the selected Ethernet mode is **Static IP**, enter an address for the primary DNS server. If DNS is not required, this field may be left blank.

Secondary DNS server

If the selected Ethernet mode is **Static IP**, enter an address for the secondary DNS server. If DNS is not required, this field may be left blank.



If the Primary DNS server is not configured or unresponsive, the Secondary DNS server address will be used.

Ethernet speed

This option allows you to reduce the power consumption of your TitanSMA and the device it is communicating with, such as a modem, by restricting the Ethernet speed that is used to communicate between devices during auto-negotiation. The default setting is **Auto**, which will attempt to use the maximum 100Base-T, if available.

To reduce the power consumption of your TitanSMA select **10BaseT** from the drop-down list. This typically reduces power consumption by more than 100 mW relative to 100Base-T.

4.6 Continuous Data Archive

The TitanSMA Continuous Data Archive feature allows you to continuously archive MiniSEED data and SOH data (optional) to a removable SD card. Using the [Archive period](#), [MiniSEED output file](#),

[Archive channel list](#) and [SOH archive format](#) filters you can specify the information to be archived. Additionally you can specify folder names and archive file names using the [Archive directory pattern](#) and [Archive filename pattern](#) options for MiniSEED data, and [SOH archive directory pattern](#) and [SOH archive filename pattern](#) options for SOH data.

Before you enable this feature, make sure that you have inserted an SD card (formatted as FAT32) into the SD card slot behind the [media bay door](#) of the TitanSMA.



In addition to [streaming data](#) from the TitanSMA to a network application or device and archiving data to a removable SD card, you can also retrieve time series and SOH data directly from the TitanSMA's **internal storage**¹ by downloading it from the [Maintenance](#) page to your computer. In addition, the TitanSMA implements a web service data download interface that enables access to data centres that support FDSN web services. See the [Web Service data download interface API](#).

Enable continuous data archive

Select this check box to allow the TitanSMA to continuously write MiniSEED data files to the SD card. Each file contains multiple 512-byte MiniSEED records of waveform data. You can specify what data to include in a file using the [MiniSEED output files](#) and [Archive channel list](#) options. See [Archive directory pattern](#) and [Archive filename pattern](#) for configuration guidelines.

Archive period [min]

Select the amount of data in minutes to be written to each file.

The number of 512-byte MiniSEED records contained in each file is determined by the duration selected here.

MiniSEED output files

Select the number of output files to be generated for each archive period: one file per channel or one file per station.

The **per channel** option produces many small files. The **per station** option produces one large file.

¹The device writes all of the data it receives to its Primary Internal Storage. The internal storage works like a ring buffer and it wraps around when it is full and records over the oldest data.

Archive channel list

This field allows you to create a filter to select which data to archive, by channel, using the SCNL (Station, Channel, Network, and Location) naming convention. Before you can filter the data, you need to configure the network, station, location, and channel codes. See the configuration setting guidelines for "Channel Naming" on page 48 and raw TCP receivers [Location and channel code](#).

The format for specifying SCNL elements in a filter is NN.SSSSS.LL.CCC, where NN is the network code, SSSSS is the station code, LL is the location code, and CCC is the channel code. The S, C, and N elements must be represented in the filter and each element must be separated by a dot (.). The L (Location) element is optional. Therefore, if the location code is not being used, then the format should be NN.SSSSS.CCC

Tips for creating filters

- use an asterisk (*) to represent one or more characters in a channel naming element. To include all available data, type an asterisk (*) in the **Archive channel list** field with no other characters.
- use an exclamation point (!) to exclude a network, station, location, or channel. The exclamation point always has to be placed before the SCNL element that should be excluded.

Examples:

- a. For the channel list filter `XX.*.*.*`, data is archived for all of the channels in the XX network.
- b. For the channel list filter `XX.*.*.*Z`, data is archived for all of the Z channels in the XX network.
- c. A filter can be created for a specific channel. For example, for the channel list filter `XX.STN01.LO.HHZ`, data is archived for the specified channel.
- d. For the channel list filter `!XX.*.*.*`, data is not archived for any of the channels in the XX network.
- e. For the channel list filter `XX.*.*.* ,YY.STN01.*.*`, data is archived for all of the channels in the XX network and all of the channels from STN01 in the YY network.
- f. For the channel list filter `XX.*.*.SOH`, if all SOH channels are called SOH, all SOH data is archived for the XX network.

Archive directory pattern

Use this field to configure the pattern for naming the digitized time-series data archive directories. For example, based on the pattern $\${Y}/\${M}$, the resulting archive directory name for January 23, 2017 would be 2017/01.

You can also use SeisComP Data Structure conventions to configure the naming pattern. In this instance a commonly used pattern is $\${Y}/\${N}/\${S}/\${C}.D$, where D indicates that the data type is waveform. For example, based on this SeisComP Data Structure pattern, the resulting archive directory name for the HHZ channel of the centaur-6_3-0345 instrument would be 2017/XX/STN01/HHZ.D/

Configuration limitations. Keep in mind the following limitations when configuring the Archive directory pattern:

- If the selected **MiniSEED output files** option is **Per station**, $\${C}$ and $\${L}$ must be excluded from the pattern string.
- Optionally, you can add a leading and a trailing slash (/) to the archive directory pattern string. For example: $\${Y}/\${M}/\${D}$ and $/\${Y}/\${M}/\${D}/$ will result in the same output.
- Do not add dots (.) before or after a slash.
- A space can be used if it is not followed by a slash or if it is not at the end of the configuration string. For example, where # represents a space $/\#a/$ is a valid configuration, the following are not valid configurations $/\#/$, and $/a\#/b\#$.
- You will get an error message if the **Archive directory pattern = SOH directory pattern** AND the **Archive filename pattern = SOH archive filename pattern**.

See "Archive pattern naming parameters" on page 57 for more parameter descriptions.

Archive filename pattern

Use this field to configure the pattern for naming the archived MiniSEED files. For example, based on the filename pattern $\${N}.\${S}.\${L}.\${C}_\${ID}_\${TIME}.miniseed$, an archived MiniSEED file may have the name XX.STN01.LO.HHZ_centaur-6_0345_20130912_073356.miniseed

You can also use SeisComP Data Structure conventions to configure the naming pattern. In this instance a commonly used pattern is $\${N}.\${S}.\${L}.\${C}.D.\${Y}.\${J}$, where D indicates that the data type is waveform.

Define date and time. To define the date and time you can use any of the following naming patterns in place of the default pattern `${TIME}`:

- `${Y}${M}${D}_${h}${m}${s}`
- `${Y}.${M}.${D}-${h}.${m}.${s}`
- `${Y}${J}_${h}${m}${s}`

Configure filename extension. The default filename pattern includes the extension `.miniseed`. To configure the filename extension to something other than the default you can

- replace the extension with something else. For example, replacing the extension name with **data** will give you the following pattern: `${N}.${S}.${L}.${C}_${ID}_
${TIME}.data`
- remove the extension altogether. The resulting pattern will be `${N}.${S}.${L}.${C}_
${ID}_${TIME}`

Configuration limitations. Keep in mind the following limitations when configuring the Archive filename pattern:

- If the MiniSEED output files option is set to **Per channel** you must include `${C}` in the pattern string.
- If the MiniSEED output files option is set to **Per station**
 - you must include `${S}` in the pattern string.
 - you must exclude `${C}` and `${L}` from the pattern string.
- Do not add dots (.) before or after a slash.
- A space can be used if it is not followed by a slash or if it is not at the end of the configuration string. For example, where # represents a space `/#a/` is a valid configuration, the following are not valid configurations `/#/`, and `/a#/b#`.

See "Archive pattern naming parameters" on page 57 for more parameter descriptions.

Include SOH archive

Select this check box if you want to archive SOH data files to the SD card.

The SOH data files are separate files and they are stored in a folder called **soh**. See [SOH archive directory pattern](#) and [SOH archive filename pattern](#) for configuration guidelines.

SOH archive format

If **Include SOH archive** is checked, select the format for archiving the SOH files.



Archiving SOH data in the CSV format is time consuming and might impact the performance of the device.

SOH archive directory pattern

Use this field to configure the pattern for naming the SOH archive directories. For example, based on the pattern $\${Y}/\${M}/soh$, the resulting archive directory name for January 23, 2017 would be 2017/01/soh

You can also use SeisComp Data Structure conventions to configure the naming pattern. In this instance a commonly used pattern is $\${Y}/\${N}/\${S}/\${C}.S$, where S indicates that the data type is SOH. For example, based on this SeisComp Data Structure pattern, the resulting archive directory name for the SOH data for the centaur-6_3-0345 instrument would be 2017/XX/STN01/SOH.S/

Configuration limitations. Keep in mind the following limitations when configuring the SOH archive directory pattern:

- If the selected **SOH archive format** is **CSV**, the user-configured channel name defined by $\${C}$ will be replaced with a hard-coded name, for example `EnvironmentSOH`.
- If the selected **SOH archive format** is **MiniSEED**, all SOH channels are included in one file, per period.
- Optionally, you can add a leading and a trailing slash (/) to the archive directory pattern string. For example: $\${Y}/\${M}/\${D}$ and $/\${Y}/\${M}/\${D}/$ will result in the same output.
- Do not add dots (.) before or after a slash.
- A space can be used if it is not followed by a slash or if it is not at the end of the configuration string. For example, where # represents a space `/#a/` is a valid configuration, the following are not valid configurations `/#/`, and `/a#/b#`.
- You will get an error message if the **Archive directory pattern = SOH directory pattern** AND the **Archive filename pattern = SOH archive filename pattern**.

See "Archive pattern naming parameters" on the next page for more parameter descriptions.

SOH archive filename pattern

Use this field to configure the pattern for naming the archived SOH files. For example, based on the filename pattern $\${N}.\${S}.\${L}.\${C}_\${ID}_\${TIME}.miniseed$, an archived SOH

file may have the name `XX.STN01.LO.HHZ_centaur-6_0345_20130912_073356.miniseed`

You can also use SeisComp Data Structure conventions to configure the naming pattern. In this instance a commonly used pattern is `#{N}.#{S}.#{L}.#{C}.S.#{Y}.#{J}`, where `S` indicates that the data type is SOH.

Define date and time. To define the date and time you can use any of the following naming patterns in place of the default pattern `#{TIME}`:

- `#{Y}#{M}#{D}_#{h}#{m}#{s}`
- `#{Y}.#{M}.#{D}-#{h}.#{m}.#{s}`
- `#{Y}#{J}_#{h}#{m}#{s}`

Configure filename extension. The default filename pattern includes the extension `.miniseed`. To configure the filename extension to something other than the default you can

- replace the extension with something else. For example, replacing the extension name with **data** will give you the following pattern: `#{N}.#{S}.#{L}.#{C}_#{ID}_#{TIME}.data`
- remove the extension altogether. The resulting pattern will be `#{N}.#{S}.#{L}.#{C}_#{ID}_#{TIME}`

Configuration limitations. Keep in mind the following limitations when configuring the SOH archive filename pattern:

- If the selected SOH archive format is CSV, the user-configured channel name defined by `#{C}` will be replaced with a hard-coded name, for example `environmental`.
- If the selected SOH archive format is MiniSEED, all SOH channels are included in one file, per period.
- Do not add dots (.) before or after a slash.
- A space can be used if it is not followed by a slash or if it is not at the end of the configuration string. For example, where `#` represents a space `/#a/` is a valid configuration, the following are not valid configurations `/#/`, and `/a#/b#`.

See "Archive pattern naming parameters" below for more parameter descriptions.

Archive pattern naming parameters

The following parameters can be used when configuring filename or directory patterns.

- `{N}` is the network name
- `{S}` is the station name
- `{L}` is the location name
- `{C}` is the channel name
- `{ID}` is the instrument ID
- `{TIME}` is the start time for the data archive in YYYYMMDD_hhmmss format
- `{Y}` is 4-digit year
- `{M}` is 2-digit month
- `{D}` is 2-digit day of the month
- `{J}` is Julian day (day of the year)
- `{h}` is 2-digit hour of the day
- `{m}` is 2-digit minutes of the hour
- `{s}` is 2-digit seconds of the minute

4.7 Data Streaming

You can configure the TitanSMA to **stream**¹ time-series data, SOH data, triggers, alerts, and raw data to one or more data acquisition servers, such as Nanometrics Apollo Server using NP protocol, or to third-party systems using the TitanSMA SeedLink server feature. NP format data is streamed using a User Datagram Protocol (UDP) socket or Hypertext Transfer Protocol (HTTP/TCP).

SeedLink data streaming is initiated by a SeedLink client requesting data from the TitanSMA, which then streams SeedLink data using Transmission Control Protocol (TCP). See the following sections for more information:

[NP UDP/HTTP Streaming](#)

[SeedLink Streaming](#)

[Throttle](#)

[Fragmentation](#)

¹The transfer of packets of data at a steady high-speed rate from the device to downstream devices and applications.

4.7.1 NP UDP/HTTP Streaming

Name

The name of the streamer.

Enable

Select this option to enable the streaming of data.

Stream primary time series

Select this option to stream primary time series data.

Stream secondary time series

Select this option if you have enabled [secondary output](#).

Stream environmental SOH

Select this option to stream environmental SOH data.

Environmental SOH for the TitanSMA includes the following data:

- Voltages
- Temperature
- Sensor SOH
- Timing information

Stream system SOH

Select this option to stream system SOH data to a downstream network management or monitoring tool, such as Antares Network Management.

Antares Network Management is a network management and diagnostic tool that allows you to assess the overall status of the network at a glance and to drill down into network issues in a wide range of areas including power, data availability, timing, latency, configuration, and firmware versions. Antares Network Management uses SOH data, log files, and configuration information available from the various assets in the network as well as data derived by monitoring data availability, latency, and error correction workload to provide you with this picture of network

performance. Contact Nanometrics Technical Support for more information.

System SOH for the TitanSMA includes the following data:

- Internal storage statistics
- Data acquisition statistics

Stream triggers/events

Select this option to stream triggers and events. For **trigger**¹ settings, see also [Trigger Detectors](#) and [Trigger Input Filters](#). For **event**² settings, see [Events](#).

Stream alerts

Select this option to stream alerts generated by the TitanSMA for events such as start-ups, shut downs, and major errors.

Alert messages include a time stamp and a brief description. These messages are also displayed on the [Health](#) page.

Stream raw data

Select this option to stream raw data that comes from an external source.

The raw data is inserted into an NP packet and streamed in the NP format.



[Raw TCP Receiving](#) must be configured and enabled before you can stream raw data.

Channel list

After you have selected the type of data you want the TitanSMA to stream, you have the option to use a filter to specify exactly which channels the TitanSMA streams.

¹A message generated by the device when the STA/LTA ratio for a channel goes above the configured trigger on ratio or when the configured threshold value is exceeded. Each trigger is assigned a number of votes (on the source device) that it casts towards getting an event declared.

²Seismic activity that is detected and declared by the instrument using a voting system and threshold values or STA/LTA trigger algorithms.

The filter is a comma-separated list of the SCNL (Station, Channel, Network, and Location) names of the channels you want streamed. The network, station, location, and channel codes used in the SCNL list are defined in the [Channel Naming settings](#) and in the [location and channel code settings](#) of the raw TCP receivers.

You can use an asterisk (*) to represent one or more characters in a channel name and an exclamation point (!) to exclude a network, station, location, or channel. The exclamation point always has to be placed before the SCNL element that should be excluded.

The format for specifying SCNL elements in a filter is NN.SSSSS.LL.CCC, where NN is the network code, SSSSS is the station code, LL is the location code, and CCC is the channel code. The S, C, and N elements must be represented in the filter and each element must be separated by a dot (.). The L (Location) element is optional. Therefore, if the location code is not being used, then the format should be NN.SSSSS.CCC

Examples:

- a. Data is streamed for all of the channels in the XX network `XX.*.*`
- b. Data is streamed for all of the Z channels in the XX network `XX.*.*Z`
- c. Data is streamed for the specified channel `XX.STN01.LO.HHZ`
- d. Data is not streamed for any of the channels in the XX network `!XX.*.*`
- e. Data is streamed for all of the channels in the XX network and all of the channels from STN01 in the YY network `XX.*.*;YY.STN01.*`
- f. All SOH data is streamed for the XX network (if all SOH channels are called SOH) `XX.*.*.SOH`

If you do not want to filter the data, type an asterisk (*) into the box. A single asterisk means that all available data will be streamed.

Destination

A valid unicast IP address of the streaming destination in dotted decimal format.

-OR-

A valid **multicast**¹ IP address.

¹The first octet of a valid multicast IP address must be between 224 and 240, inclusive. Each of the last three octets can be any positive integer from 0 to 255.

Port number

The port number used by the TitanSMA to stream data in the NP format.



If you are streaming to Apollo Server, ensure that the Apollo Server UDP receiver is configured to listen to this port number.

ReTx strategy

Defines the manner in which requests to retransmit data are prioritized and processed.

- First-Come, First-Served - ReTx requests are processed in the order received.
- Oldest Data First, with Recent Data Threshold - ReTx requests are processed in chronological order based on the data time (oldest first) except for requests for data newer than the configured ReTx Recent Data Threshold, which are given highest priority.

ReTx recent data threshold [min]

The time in which recent requests should be processed before the oldest requests are processed.



Configure this setting if you selected Oldest Data First, with Recent Data Threshold as the ReTx Strategy.

Multicast TTL (NP UDP streaming only)

If the streaming destination address is **multicast**¹, you can increase the Time-To-Live (**TTL**)² of the packets by specifying the number of networks (routers) that the packet must cross to reach the destination.

For example, if the packets have to cross five networks to reach the destination, you should set the Multicast TTL to 5.



All of the routers must support the Time-To-Live feature. In some cases, this feature might be disabled for security reasons (Denial-of-Service attack).

¹The first octet of a valid multicast IP address must be between 224 and 240, inclusive. Each of the last three octets can be any positive integer from 0 to 255.

²Time-To-Live

4.7.2 Throttle

If you have a low-throughput link, the throttle configuration settings allow you to configure the maximum data output of the streamer.

Enable throttle

Select this option to set the maximum data throughput of the NP streamer.

Maximum throughput [bps]

The maximum throughput in bits per second.



If you have enabled the [Libra compatibility streaming](#) option, configure the maximum throughput value to be 80 per cent of the Requested Throughput Value for the attached Cygnus. Refer to your Libra user guide for more information about Cygnus.

4.7.3 Fragmentation

This feature supports data paths with components that block packets larger than a particular threshold. For instance, if you are using a router that does not allow IP fragmentation, the fragmentation configuration settings allow you to configure the maximum packet size.

Enable fragmenting

Select this option to set the maximum allowable packet size. If enabled, packets larger than the configured threshold will be broken into smaller packets.

Fragment size [B]

The maximum packet size in bytes.

Include CRC

Select this option if you want a cyclic redundancy check performed on each fragment to verify that the data is not corrupted.

4.8 Digitizer

The TitanSMA Digitizer has three time series data channels that are constantly digitizing data. The data from each of these channels is recorded and always written to the Primary Internal Storage, and is optionally written to the hot-swappable SD memory card and/or streamed to central data repositories.

You can capture data at two concurrent sample rates by enabling secondary output, and setting different sample rates on your [primary](#) and [secondary channels](#). For example, you may wish to continually stream your data at a lower sample rate on primary channels and archive data to an SD card at a higher sample rate on secondary channels.

You can also configure general settings for the TitanSMA Digitizer such as frames per packet on primary and secondary channels, as well as [input filter](#) and [detector](#) configuration settings.

4.8.1 Primary Channels

You can configure your sampling rate and set your frames per packet for your primary data channels.

Primary output type

Use this option to apply an anti-aliasing filter to decimate digitized data to the desired sample rate. Select the filter type from the drop-down list:

- **Linear phase** (also known as non-causal or acausal). Select this output type to enable a high-performance anti-aliasing filter with the flattest passband, most attenuated stopband, and no phase distortion.
- **Minimum phase** (also known as causal). Select this output type to significantly reduce signal delay (latency) of the anti-aliasing filters. Note that this output type has a somewhat reduced stopband attenuation performance than Linear phase. Its delay is frequency-dependent (not linear phase).
- **Disabled**. Select this option to turn off the output from this channel set.

The default output type is **Linear phase**. See in the Specifications section for more details.



1. The sample rates 80 Hz and 2000 Hz are not supported for **Minimum phase** filter types.
2. You can configure different output types for Primary channels and Secondary channels.

Primary sample rate [Hz]

The number of samples per second produced from each analog sensor input signal. The default is 100 Hz (100 samples per second).

Primary frames per packet

The number of standard Steim data frames per packet for transmission and storage of the primary time series data. Smaller packets reduce the streaming latency, but will greatly increase the requirements for streaming throughput and data storage.

4.8.2 Secondary Channels

If you want to capture data at two concurrent sample rates, you must enable the *Secondary output type*. You can also configure other signal processing settings for your secondary channels such as linear or minimum phase anti-aliasing filter type, or applying bandpass filtering.

Secondary output type

Use this option to apply an anti-aliasing filter to decimate digitized data to the desired sample rate. Select the filter type from the drop-down list. See "Primary output type" on the previous page for options and details.

The default output type is **Disabled**.



You can configure different output types for Primary channels and Secondary channels.

Secondary Sample rate [Hz]

The number of samples per second produced from each analog sensor input signal. The default is 100 Hz (100 samples per second).

Secondary frames per packet

The number of standard Steim data frames per packet for transmission and storage of the primary time series data. Smaller packets reduce the streaming latency, but will greatly increase the requirements for streaming throughput and data storage.

4.8.3 Bandpass Butterworth Filters

High pass order

The order of the high pass filter applied to output data. The sum of the high and low pass orders must not exceed 5. Order of zero means no high pass filter is applied.

High pass frequency [Hz]

The 3 dB corner frequency of the selected high pass filter. The ratio of this corner frequency to the sample rate must be between 0.000001 and 0.499999.

Low pass order

The order of the low pass filter applied to output data. The sum of the high and low pass orders must not exceed 5. Order of zero means no high pass filter is applied.

Low pass frequency [Hz]

The 3 dB corner frequency of the selected low pass filter. The ratio of this corner frequency to the sample rate must be between 0.000001 and 0.499999.

4.8.4 Trigger Input Filters

The trigger input filter is a common band pass filter applied to the channel data prior to being processed by the **trigger¹ detectors²**.

¹A message generated by the device when the STA/LTA ratio for a channel goes above the configured trigger on ratio or when the configured threshold value is exceeded. Each trigger is assigned a number of votes (on the source device) that it casts towards getting an event declared.

²Algorithms applied to channels and used to declare seismic signals of interest

Trigger high pass order

The order of the high pass trigger filter.

Trigger high pass frequency [Hz]

The 3 dB corner frequency, in hertz, of the high pass trigger filter.

Trigger low pass order

The order of the low pass trigger filter.

Trigger low pass frequency [Hz]

The 3 dB corner frequency, in hertz, of the low pass trigger filter.

4.8.5 Trigger Detectors

The TitanSMA uses detectors combined with a voting system to declare an event. A detector is an algorithm that is applied to a channel and is based on either a configured threshold value or a configured **STA**¹/**LTA**² ratio. As soon as the channel detector detects that the threshold value or STA/LTA ratio has been exceeded, it generates a **trigger**³ for that channel. When the TitanSMA sees this trigger, it counts how many **votes**⁴ are assigned to the channel that generated that trigger:

- If the number of votes are equal to or higher than the configured number of required votes, an event is declared with the date and time from the trigger.

¹Short Term Average

²Long Term Average

³A message generated by the device when the STA/LTA ratio for a channel goes above the configured trigger on ratio or when the configured threshold value is exceeded. Each trigger is assigned a number of votes (on the source device) that it casts towards getting an event declared.

⁴The number of votes assigned to each channel that it can cast towards getting an event declared.

The higher the number of votes, the greater the impact that the channel has on event declaration. To ensure proper event declaration, you should give zero votes to a channel that you do not want to affect the event declaration at all and a lower number of votes to channels at noisy stations.

- If not enough votes were received from the trigger, then the TitanSMA waits for additional triggers for a configured period of time to allow for transmission latency.
- If not enough votes are received within the configured period of time, the triggers are discarded and no event is declared.
- If enough votes are received, an event is declared and written to the internal storage and posted on the **Events** page. If configured, the time series data for the event is also [written to a removable media card](#).

Event declaration can happen locally using only the channels of the TitanSMA or it can happen across a network between multiple devices if you enable the option to share triggers across a network.

Type *n*

Select the type of detector for the channel.

Votes *n*

The number of votes assigned to each channel that it can cast towards getting an event declared.

The higher the number of votes, the greater the impact that the channel has on event declaration. To ensure proper event declaration, you should give zero votes to a channel that you do not want to affect the event declaration at all and a lower number of votes to channels at noisy stations.

Trigger threshold *n* [g]

The value that must be exceeded for the channel detector to generate a trigger for that channel.



Configure this setting if the selected detector type is **Threshold**.

Threshold hold off *n* [s]

The amount of time after a threshold has been exceeded that the channel detector will wait before it generates a trigger for that channel.

This setting can be used to ensure that multiple triggers are not generated if a threshold is exceeded several times in a very short period of time. Multiple triggers could result in the declaration of multiple events when really it is only one event.



Configure this setting if the selected detector type is **Threshold**.

STA time constant n [s]

The short term average time constant in seconds.

The time constant τ is related to the cutoff frequency f_c by $\tau = 1/(2\pi f_c)$.

Choose a value longer than a few periods of a typical expected seismic signal of interest, shorter than expected durations of events of interest, and not so short that excessive false triggers are generated by non-seismic noise spikes near the site.



Configure this setting if the selected detector type is **STA/LTA ratio**.

LTA time constant n [s]

The long term average time constant in seconds.

The time constant τ is related to the cutoff frequency f_c by $\tau = 1/(2\pi f_c)$.

Choose a value long enough to encompass at least several cycles of typical non-seismic, irregular noise for the site.



Configure this setting if the selected detector type is **STA/LTA ratio**.

Trigger on ratio n

The STA/LTA ratio above which the associated channel is triggered.

Choose a value low enough to be sensitive to events of interest but high enough to minimize false triggers.



Configure this setting if the selected detector type is **STA/LTA ratio**.

Trigger off ratio n

The STA/LTA ratio below which the associated channel trigger ends.

Latch LTA *n*

If you select this option, the LTA is held at the value when the channel triggered and is not updated while the channel is triggered.

If you do not select this option, the LTA continues to be calculated and updated while the channel is triggered.

In both cases, the trigger terminates either when the trigger off ratio is achieved or once the **Maximum duration** has expired.



Configure this setting if the selected detector type is **STA/LTA ratio**.

Maximum duration *n* [s]

The maximum duration of a trigger in seconds.

After this time period has expired, the trigger is ended even if the **Trigger off ratio** has not been achieved.

4.9 Events

The TitanSMA uses detectors combined with a voting system to declare an event. A detector is an algorithm that is applied to a channel and is based on either a configured threshold value or a configured **STA**¹/**LTA**² ratio. As soon as the channel detector detects that the threshold value or STA/LTA ratio has been exceeded, it generates a **trigger**³ for that channel. When the TitanSMA sees this trigger, it counts how many **votes**⁴ are assigned to the channel that generated that

¹Short Term Average

²Long Term Average

³A message generated by the device when the STA/LTA ratio for a channel goes above the configured trigger on ratio or when the configured threshold value is exceeded. Each trigger is assigned a number of votes (on the source device) that it casts towards getting an event declared.

⁴The number of votes assigned to each channel that it can cast towards getting an event declared.

The higher the number of votes, the greater the impact that the channel has on event declaration. To ensure proper event declaration, you should give zero votes to a channel that you do not want to affect the event declaration at all and a lower number of votes to channels at noisy stations.

trigger. If the number of votes are equal to or higher than the configured number of required votes, an event is declared with the date and time of the trigger. If not enough votes were received from the trigger, then the TitanSMA waits for additional triggers for a configured period of time to allow for transmission latency. If not enough votes are received within the configured period of time, the triggers are discarded and no event is declared. If enough votes are received, an event is declared and written to the internal storage and posted on the **Events** page. If configured, the time series data for the event is also [written to a removable media card](#).

Event declaration can happen locally using only the channels of the TitanSMA or it can happen across a network between multiple devices if you enable the option to share triggers across a network.

Coincidence window [s]

The window of time into which the trigger on times of the channels must fall in order for those channels to be included in the same event.

Required votes

The minimum number of votes required for the TitanSMA to declare a group of triggers as an event.

Maximum event duration [s]

The amount of time, in seconds, that the TitanSMA waits to see if the minimum number of required votes is met for event declaration. This wait time allows for transmission latency and any other delays that might occur.



The maximum event duration time should always be longer than the coincidence window duration.

Pre-event time [s]

The number of seconds of data archived before the event declaration time.

Post-event time [s]

The number of seconds of data archived after the event declaration time.

4.9.1 Events Data Archive

The TitanSMA Events Data Archive feature allows you to archive **event**¹ data and SOH data (optional) to a removable SD card. The event data can be archived in multiple industry-standard formats. Using the [MiniSEED output file](#), [Archive channel list](#) and [SOH archive format](#) filters you can specify the information to be archived. Additionally you can specify archive file names using the [Archive filename pattern](#) option for MiniSEED data, and the [SOH archive filename pattern](#) option for SOH data.

Before you enable this feature, make sure that you have inserted an SD card (formatted as FAT32) into the SD card slot behind the [media bay door](#) of the TitanSMA.



In addition to archiving event data to a removable SD card, you can also [manually declare an event](#) on the [Events](#) page.

Enable events data archive

Select this check box to allow the TitanSMA to write event data to the SD card. Each event data file is stored in a folder named for the day the event was recorded.

The folder location is `events/YYYY/MM/DD`.

You can specify what data to include in a file using the [MiniSEED output files](#) and [Archive channel list](#) options. See [Archive filename pattern](#) for configuration guidelines.



If the **per channel** option is selected for the MiniSEED output files setting, then the channel name is also added to the name of the event data file before the YYYYMMDD_HHMMSS.

MiniSEED output files

Select the number of output files to be generated for each archive period: one file per channel or one file for all instruments.

The **per channel** option produces many small files, the **per station** option produces one large file.

¹Seismic activity that is detected and declared by the instrument using a voting system and threshold values or STA/LTA trigger algorithms.

Format

Select the desired file format from the drop-down list to archive event data in that format. If the selected format is something other than MiniSEED, one archive file per channel will be created.

Archive channel list

This field allows you to create a filter to select which data to archive, by channel, using the SCNL (Station, Channel, Network, and Location) naming convention. Before you can filter the data, you need to configure the network, station, location, and channel codes. See the configuration setting guidelines for "Channel Naming" on page 48 and raw TCP receivers [Location and channel code](#).

The format for specifying SCNL elements in a filter is NN.SSSSS.LL.CCC, where NN is the network code, SSSSS is the station code, LL is the location code, and CCC is the channel code. The S, C, and N elements must be represented in the filter and each element must be separated by a dot (.). The L (Location) element is optional. Therefore, if the location code is not being used, then the format should be NN.SSSSS.CCC

Tips for creating filters

- use an asterisk (*) to represent one or more characters in a channel naming element. To include all available data, type an asterisk (*) in the **Archive channel list** field with no other characters.
- use an exclamation point (!) to exclude a network, station, location, or channel. The exclamation point always has to be placed before the SCNL element that should be excluded.

Examples:

- a. For the channel list filter `XX.*.*.*`, data is archived for all of the channels in the XX network.
- b. For the channel list filter `XX.*.*.*Z`, data is archived for all of the Z channels in the XX network.
- c. A filter can be created for a specific channel. For example, for the channel list filter `XX.STN01.LO.HHZ`, data is archived for the specified channel.
- d. For the channel list filter `!XX.*.*.*`, data is not archived for any of the channels in the XX network.

- e. For the channel list filter `XX.*.*.*`, `YY.STN01.*.*`, data is archived for all of the channels in the XX network and all of the channels from STN01 in the YY network.
- f. For the channel list filter `XX.*.*.SOH`, if all SOH channels are called SOH, all SOH data is archived for the XX network.

Archive filename pattern

Use this field to configure the pattern for naming the archived MiniSEED files. For example, based on the filename pattern `${N}.${S}.${L}.${C}_${ID}_${TIME}.miniseed`, an archived MiniSEED file may have the name `XX.STN01.LO.HHZ_centaur-6_0345_20130912_073356.miniseed`

Define date and time. To define the date and time you can use any of the following naming patterns in place of the default pattern `${TIME}`:

- `${Y}${M}${D}_${h}${m}${s}`
- `${Y}.${M}.${D}-${h}.${m}.${s}`
- `${Y}${J}_${h}${m}${s}`

Configure filename extension. The default filename pattern includes the extension `.miniseed`. To configure the filename extension to something other than the default you can

- replace the extension with something else. For example, replacing the extension name with **data** will give you the following pattern: `${N}.${S}.${L}.${C}_${ID}_${TIME}.data`
- remove the extension altogether. The resulting pattern will be `${N}.${S}.${L}.${C}_${ID}_${TIME}`

Configuration limitations. Keep in mind the following limitations when configuring the Archive filename pattern:

- If the MiniSEED output files option is set to **Per channel** you must include `${C}` in the pattern string.
- If the MiniSEED output files option is set to **Per station**
 - you must include `${S}` in the pattern string.
 - you must exclude `${C}` and `${L}` from the pattern string.
- Do not add dots (.) before or after a slash.
- A space can be used if it is not followed by a slash or if it is not at the end of the configuration string. For example, where # represents a space `/#a/` is a valid configuration, the following are not valid configurations `/#/`, and `/a#/b#`.

See [Archive pattern naming parameters](#) for more parameter descriptions.

Include SOH archive

Select this check box if you want to archive SOH data files to the SD card.

The SOH data files are separate files and they are stored in a folder called **soh**. The location of this folder is **YYYY/MM/DD/soh**.

SOH archive format

If **Include SOH archive** is checked, select the format for archiving the SOH files.



Archiving SOH data in the CSV format is time consuming and might impact the performance of the device.

SOH archive filename pattern

Use this field to configure the pattern for naming the archived SOH files. For example, based on the filename pattern `${N}.${S}.${L}.${C}_${ID}_${TIME}.miniseed`, an archived SOH file may have the name `XX.STN01.LO.HHZ_centaur-6_0345_20130912_073356.miniseed`

Define date and time. To define the date and time you can use any of the following naming patterns in place of the default pattern `${TIME}`:

- `${Y}${M}${D}_${h}${m}${s}`
- `${Y}.${M}.${D}-${h}.${m}.${s}`
- `${Y}${J}_${h}${m}${s}`

Configure filename extension. The default filename pattern includes the extension `.miniseed`. To configure the filename extension to something other than the default you can

- replace the extension with something else. For example, replacing the extension name with **data** will give you the following pattern: `${N}.${S}.${L}.${C}_${ID}_${TIME}.data`
- remove the extension altogether. The resulting pattern will be `${N}.${S}.${L}.${C}_${ID}_${TIME}`

Configuration limitations. Keep in mind the following limitations when configuring the SOH archive filename pattern:

- If the selected **SOH archive format** is CSV, the user-configured channel name defined by `#{C}` will be replaced with a hard-coded name, for example `environmental`.
- If the selected **SOH archive format** is MiniSEED, all SOH channels are included in one file, per period.
- Do not add dots (.) before or after a slash.
- A space can be used if it is not followed by a slash or if it is not at the end of the configuration string. For example, where # represents a space `/#a/` is a valid configuration, the following are not valid configurations `/#/`, and `/a#/b#`.

See [Archive pattern naming parameters](#) for more parameter descriptions.

Archive pattern naming parameters

The following parameters can be used when configuring filename or directory patterns.

- `#{N}` is the network name
- `#{S}` is the station name
- `#{L}` is the location name
- `#{C}` is the channel name
- `#{ID}` is the instrument ID
- `#{TIME}` is the start time for the data archive in YYYYMMDD_hhmmss format
- `#{Y}` is 4-digit year
- `#{M}` is 2-digit month
- `#{D}` is 2-digit day of the month
- `#{J}` is Julian day (day of the year)
- `#{h}` is 2-digit hour of the day
- `#{m}` is 2-digit minutes of the hour
- `#{s}` is 2-digit seconds of the minute

4.9.2 Trigger/Event Sharing

The TitanSMA has the ability to send and receive **triggers**¹ and **events**² and from other devices via a multicast **UDP**³. The **votes**⁴ associated with triggers received from other devices are used in the [event detection and declaration process](#) and the events received from other devices are displayed and downloadable on the **Events** page of the local device.

Share triggers

Select this option to enable trigger sharing.

If you enable this option, event declaration will happen both locally, using only the three channels of the local device, and across all of the devices in your network.

Share events

Select this option to enable events sharing.

If you enable this option, you can view and download the events received from other devices on the **Events** page of this device.

Multicast group

A valid **multicast**⁵ IP address.

¹Messages generated by the instrument when the STA/LTA ratio for one or more channels go above the configured trigger on ratio or when the configured threshold value is exceeded. Each trigger is assigned a number of votes (on the source device) that it casts towards getting an event declared.

²Seismic activity that is detected and declared by the instrument using a voting system and threshold values or STA/LTA trigger algorithms.

³User Datagram Protocol

⁴The number of votes assigned to each channel that it can cast towards getting an event declared. The higher the number of votes, the greater the impact that the channel has on event declaration. To ensure proper event declaration, you should give zero votes to a channel that you do not want to affect the event declaration at all and a lower number of votes to channels at noisy stations.

⁵The first octet of a valid multicast IP address must be between 224 and 240, inclusive. Each of the last three octets can be any positive integer from 0 to 255.



All devices that share triggers and/or events have to use the same multicast IP address and port number.

Port number

The port number used by the TitanSMA to share triggers and/or events with other devices (send and receive)



All devices that share triggers and/or events have to use the same multicast IP address and port number.

Multicast TTL

You can increase the Time-To-Live (TTL) of the trigger data packets by specifying the number of networks (routers) that the trigger data packets must cross to reach their destination.

For example, if the trigger data packets have to cross five networks to reach their destination, you should set the Multicast TTL to 5.

4.9.3 Event Data Products

You can configure the TitanSMA to calculate peak ground motion data products. When this feature is enabled, the TitanSMA calculates the **PGA**¹, **PGV**², and **PGD**³ values for each [declared event](#), writes the calculated values to the **internal storage**⁴ with the event, and posts them on the **Events** page.



The PGA reported by the TitanSMA is based on measurements of the acceleration in the two horizontal directions (north-south and east-west).

¹Peak Ground Acceleration

²Peak Ground Velocity

³Peak Ground Displacement

⁴The device writes all of the data it receives to its Primary Internal Storage. The internal storage works like a ring buffer and it wraps around when it is full and records over the oldest data.

Enable events data products

Select this check box to allow the TitanSMA to calculate peak ground motion data products for each event.

You can view the calculated PGA, PGV, and PGD values on the [Events](#) page.

Source digitizer channels

Select the channels used to calculate the data products.

4.9.4 Configure Email Notifications for Declared Events

TitanSMA ships with three configuration template files that can be used to configure the automatic sending of email notifications when events are declared and completed. Once these files have been configured, two emails are sent automatically for each event. The first email is sent as soon as the event is declared and the second email is sent when the event has completed. The emails are sent to the email addresses specified in the configuration files.



Example email subject line: NX.PVEA1 Event 2013-05-10T18:09:19.015Z

Example email body:

Event complete 2013-05-10T18:09:19.015Z (titanSMA_0104)

Maximum PGA 1.40693125E-1 g @ NX.PVEA1 (titanSMA_0104)



If [Ethernet Mode](#) is set to Static IP, email notifications cannot be configured.

See the Help for more information on event detection and declaration. You can access the help by clicking **Help** in the upper-left corner of the TitanSMA web interface.

To configure the automatic sending of email notifications

1. Use the following commands to copy the three configuration template files that shipped with TitanSMA to /etc/nanometrics/config and remove the suffix (.template) from the copy:

```
cp /usr/share/nanometrics/event-email/conf/event-email.conf.template
/etc/nanometrics/config/event-email.conf
```

```
cp /usr/share/nanometrics/event-email/conf/event-
```

```
declared.conf.template /etc/nanometrics/config/event-declared.conf
```

```
cp /usr/share/nanometrics/event-email/conf/event-complete-email.-  
conf.template /etc/nanometrics/config/event-complete-email.conf
```

The template files are called **event-email.conf.template**, **event-declared-email.conf.template**, and **event-complete-email.conf.template** and they are located in `/usr/share/nanometrics/event-email/conf`.

2. Modify the email server settings contained in **event-email.conf** so that they match the outgoing mail settings for your network and specify the email addresses of all intended recipients.
3. Modify the variables contained in **event-declared-email.conf** to determine the content of the event declared email notification (the first email that is sent).

The first line of this file is the subject of the email and the other lines in the file are the body of the email. The available variables are as follows:

- `event_start` – The time the event was declared
 - `event_num_triggers` – The number of triggers for the declared event
 - `stationName` – The SCNL information for the local device (the SCNL information for a device is configured in the Channel Naming settings)
 - `instrumentID` – The ID of the local device as shown at the top of the user interface of the device
4. Repeat step 3 for the variables in **event-complete-email.conf** to determine the content of the event completed email notification (the second email that is sent).

The following variables are available for the event completed email notification in addition to the ones listed in step 3:

- `event_pga` – The PGA of the local device, calculated after the post-event time has elapsed (see Configuration -> Events)
- `max_pga` – The highest PGA value from the devices in a group, calculated after the post-event time has elapsed (see Configuration -> Events)
- `max_pga_instrumentID` – The ID of the device with the highest PGA value

- max_pga_stationName – The SCNL information for the device with the highest PGA (the SCNL information for a device is configured in the Channel Naming settings)

4.10 Power



If the power supply voltage is below the configured **Power on** threshold, the TitanSMA will not power up. If this happens, you can bypass the power supply threshold settings and force the TitanSMA to power up by pressing the **Force Power On** button behind the media bay door to override this threshold.



The voltage reported by the TitanSMA may be lower than the voltage supplied to the TitanSMA due to power cable losses as well as small voltage drops in protective circuitry inside the TitanSMA.

Power on [mV]

When the external power [supply voltage](#) rises above the Power on threshold, the TitanSMA powers up immediately.



If the current external power supply voltage is less than a newly committed **Power on** threshold, then the TitanSMA will not automatically power up the next time the power is disconnected and reconnected unless the **Force Power On** button behind the media bay door is pressed to override these thresholds.

Low voltage shutdown [mV]

When the external power supply voltage falls below the Low voltage shutdown threshold, the TitanSMA performs a safe shutdown.



If the current external power supply voltage is less than a newly applied **Low voltage shutdown** value, then the TitanSMA will automatically shut down. If not committed, the TitanSMA will revert to the previous Low voltage shutdown value.

Low voltage disconnect [mV]

When the external power supply voltage falls below the Low voltage disconnect threshold, the TitanSMA powers off immediately.



Set the disconnect to a value that will properly protect the battery for your power supply.

4.11 Raw TCP Receiving

You can configure the TitanSMA to acquire raw data from a TCP server using a TCP socket. For example, you can configure the TitanSMA to receive **BINEX**¹ data from a Trimble® NetR9 GNSS Reference Receiver.

You can create and configure raw data TCP receivers to acquire raw data. Once the raw data has been acquired, you can configure a streamer to stream the data to a data acquisition server. Before the raw data is streamed, it is inserted into an NP packet so that it can be streamed in the NP format.

Name

The name of the raw data TCP receiver.

Enable

Select this option to enable the raw data TCP receiver to receive data.

Server IP address

The unicast IP address of the TCP server.

Port number

The number of the port used by the TCP server to stream data. The raw data TCP receiver acts as a TCP client and connects to this port and then the external device streams data to the TitanSMA.

For example, you configure this port number in the I/O Configuration settings of a Trimble® NetR9.

¹BINEX is a binary exchange format for GPS and GNSS data. For more information on BINEX, see <http://binex.unavco.org/binex.html>.

TCP socket timeout [s]

The maximum amount of time in seconds that the modem will wait for data from the TCP socket before disconnecting from the socket.

After the modem has disconnected from the socket, it will reconnect and wait for a response again.

Raw data type

Select the format of the raw data from the list.

Currently, the only available format is BINEX.



Make sure that the TCP server (for example, a Trimble® NetR9) is configured to stream data to the TitanSMA in the BINEX format.

Channel index

A number from 2001 to 2099 used to identify the raw data channel.

Each raw data TCP receiver should have a unique channel index number.



You only need to change this number if you are enabling more than one raw data TCP receiver on a single TitanSMA.

Raw packets per NP packet

The number of packets the TitanSMA waits for before it creates an NP packet.

Location and channel code

A three character alphanumeric code for the channel name.

-OR-

A two character alphanumeric code for the location and a three character alphanumeric code for the channel name, separated by a dot.

Example: L0.RAW

These codes are used for filtering the data that is streamed to a downstream device and should be unique for each raw data TCP receiver. For more information on filtering, see the description of the NP UDP/HTTP streamer [Channel list](#) configuration setting.



The station and network codes are defined by the [Channel Naming](#) configuration settings.

4.12 SeedLink Server

TitanSMA can be configured to act as a SeedLink server for other SeedLink clients. (See a <http://www.iris.edu/data/dmc-seedlink.htm>) Any time series data in the **internal storage**¹ of the TitanSMA can be converted into the 512-byte MiniSEED format and retrieved by SeedLink clients from the TitanSMA.

Channel names are used in the file headings and default file names of the data that is retrieved from the internal storage. These channel names act as labels and help the SeedLink clients identify the data. Before you enable a SeedLink server, ensure that you have configured the [channel name settings](#).

Name

The unique name of the SeedLink server.

Once you have configured the SeedLink server, its name will appear in the left pane of the Configuration dialog box, under the SeedLink server section of the tree. Select the name of the SeedLink server to edit its settings.

Enable

Select this check box to allow TitanSMA to stream data from this SeedLink server.

Clear this check box to disable this SeedLink server, stopping data acquisition from this source.

Port

The port number for the SeedLink server.

¹The device writes all of the data it receives to its Primary Internal Storage. The internal storage works like a ring buffer and it wraps around when it is full and records over the oldest data.

The SeedLink clients have to be configured to use this port number to acquire data from the TitanSMA SeedLink server.

Maximum backfill packets

Use this option to configure the maximum number of 512-byte SeedLink packets that the SeedLink interface will attempt to re-transmit in response to DATA requests.

- To limit each DATA backfill request to a maximum number of SeedLink packets, enter a positive integer in the field. For example, if you enter **200** in the field, the maximum number of packets that will be backfilled is 200.

When a maximum number of packets is configured, the most recent historical data are provided so that there is no gap between the re-transmitted data and the real-time data.

- To allow unlimited backfill, enter the value **-1**.
- To disable backfilling, enter the value **0**.

You can configure a different limit for each configured SeedLink server.

The default is **-1** so that no limits are applied to SeedLink backfill requests.

Short term complete enable

Select this option to ensure that the SeedLink server sends data in chronological order.

If a packet is missed, the SeedLink server will wait up to the set threshold time (**Short term complete threshold [s]**) before sending any more packets. Once the threshold time is crossed, the SeedLink Server will send the next available packet and ignore the missed packet even if it is received later.



Short term complete should be used with Hydra and Earthworm slink2ew clients.

Short term complete threshold [s]

The number of seconds the SeedLink server will wait to receive a missed packet before continuing to send data.



Configure This threshold value is only if the [Short term complete enable](#) option is selected.

Throttle

The throttle fields display under each SeedLink server added, allowing you to enable a throttle and to specify the maximum throughput bit rate:

- Enable throttle is selected by default. Uncheck this field if you do not want to limit the network transfer rate.
- Maximum throughput bit rate (bps) allows you to specify the maximum output bit rate. The default maximum is 2056000 bps.

4.13 State of Health (SOH) Settings

Internal SOH report interval [s]

The SOH reporting rate of the SOH channels (for example, GNSS, time, and storage). Default: 60 s.

Frames per packet

Number of frames used in each SOH packet. A smaller value means less latency, but more overhead.

4.14 Timing Source

The Timing source option allows you to specify the time reference for the internal clock of the instrument, which in turn timestamps the digitized data. In most cases GNSS timing will be used since it is very accurate, and works independently of network connections or other time servers, but network timing options of Precision Time Protocol (PTPv1) and Network Time Protocol (NTP) can also be selected, as well as a free running clock, which by definition has no time reference. Independently of what time source the TitanSMA uses, it can also be configured to supply either PTPv1 or NTP network timing to other TitanSMA units.

Consider the following when selecting a time source for your TitanSMA:

- **availability of equipment.** To use GNSS as the configured time source, the instrument must have a GNSS or GPS antenna.
- **installed location of the instrument.** To use GNSS as the configured time source, the instrument must be installed so that its GNSS/GPS antenna has a view of the sky. If the instrument is below ground, within a structure or under water, you can configure the time source as PTP, NTP or free-running.

- **importance of timing accuracy.** GNSS provides the most accurate timing followed by PTP, then NTP and finally free-running.

The TitanSMA requires a timing source to timestamp samples relative to UTC. Four timing source options are available to Nanometrics instruments—GNSS, PTP, NTP, and free running. The following factors may help you to determine the best timing source option for your system:

- GNSS is convenient, economical and very precise, and is a good option if the instrument is situated so that its GNSS/GPS antenna has a view of the sky. GNSS is therefore not suitable for subsurface applications such as mining, seismic stations in caves, submarine, and interior structural monitoring. In these instances, some of the following timing source configuration options can be used.
- PTP can be used where another TitanSMA or another Nanometrics instrument such as a Centaur on the local subnet can be configured as a PTPv1 network timing source. Typically this is a system with GNSS-derived timing, but it can also be a system that is deriving its timing from NTP or even free-running. This type of system can provide very good accuracy if the LAN is appropriately engineered and network traffic congestion does not degrade timing packet transmission. PTPv1 uses multicast, so the master and clients must be on the same subnet.
- NTP can be used instead of PTP where a PTP source is not available or practical. NTP is a simpler less precise protocol for synchronizing computers' time-of-day across the Internet, and it is not restricted to a single subnet. NTP can use any public NTP server on the Internet. Very good timing accuracy can also be achieved when another local TitanSMA, TitanEA or Centaur acts as an NTP server for the TitanSMA.
- The importance of relative time synchronization versus absolute time accuracy. For example, where it is important that a cluster of local stations have precisely matched relative timing but absolute agreement to UTC time is not as important, one unit can be configured to source its time from a remote NTP server or even free-run, then in turn serve PTP time (or even NTP time) to neighbouring stations.
- Free running can be used in situations where time may be set manually and allowed to run at the accuracy of the internal oscillator, with the time manually reset at intervals if necessary.

The remainder of this section provides some sample configurations as well as guidelines for configuring the different timing sources.

4.14.1 Sample Timing Configurations

This section provides some examples of networks where there may be one or more instruments on the surface that can use GNSS and several instruments underground/sea that cannot use GNSS. All units are connected by Ethernet to a local network which may be connected to the Internet from which an NTP server is accessible (example: time.nrc.ca).

Example 1: GNSS master with PTP clients

In this scenario, all surface instruments have GNSS, with one or more of these units configured as an PTP server. All underground/sea instruments are PTP clients using the surface instruments as their source. All units must be connected to the same subnet. This is the best situation with an accurate local PTP server that minimizes network effects on timing accuracy.

The basic configuration instructions are as follows:

1. For all surface instruments, select **GNSS** from the **Time source** drop-down list.
2. For one or more of the surface instruments, select **PTP** from the **Time sharing** drop-down list.
3. For all underground/sea instruments, select **PTP** from the **Time source** drop-down list.

Example 2: Free-running master and PTP clients

In this scenario, all of the instruments are connected via an Ethernet network on the same subnet, but none of them have access to remote NTP or GNSS. One of the underground/sea units is configured as Free running. This same underground/sea unit is also acting as a PTP server for the other instruments. This should provide excellent relative timing among the instruments because they are tracking the one local instrument PTP server.

The basic configuration instructions are as follows:

1. On one instrument, select **Free-running** from the **Time source** drop-down list, and select **PTP** from the **Time sharing** drop-down list.
2. On the other instruments, select **PTP** from the **Time source** drop-down list.

Example 3: GNSS master serving NTP clients

In this scenario, all surface instruments have GNSS, with one of these units configured as an NTP server. All underground/sea instruments are NTP clients using the surface instrument as their

source. This is the best situation with an accurate local NTP server that minimizes network effects on timing accuracy.

The basic configuration instructions are as follows:

1. For all surface instruments, select **GNSS** from the **Time source** drop-down list.
2. For one of the surface instruments, select **NTP** from the **Time sharing** drop-down list.
3. For all underground/sea instruments,
 - a. select **NTP** from the **Time source** drop-down list.
 - b. in the **NTP server address** field, enter the hostname or IP address of the surface instrument that is configured for Time sharing.

Example 4: All TitanSMA are NTP clients to an Internet NTP server

In this scenario, there are no surface instruments with GNSS that can act as NTP servers. All underground/sea instruments are NTP clients using the same remote NTP server as their source. This provides the most accurate absolute time available by NTP, but the relative timing of the instruments among themselves is no better than that of the NTP server.

The basic configuration instructions are as follows:

1. For all underground/sea instruments,
 - a. select **NTP** from the **Time source** drop-down list.
 - b. in the **NTP server address** field, enter the hostname or IP address of the remote NTP server.

Example 5: One NTP-timed TitanSMA serves NTP to the others

In this scenario, there are no surface instruments with GNSS that can act as NTP servers. One of the underground/sea units is an NTP client using a remote NTP server as its source. This same underground/sea unit is also acting as an NTP server for the other instruments. This should provide somewhat better relative timing among the instruments because they are tracking the one local instrument NTP server.

The basic configuration instructions are as follows:

1. For all underground/sea instruments, select **NTP** from the **Time source** drop-down list.
2. For one of the underground/sea instruments,
 - a. select **NTP** from the **Time sharing** drop-down list.
 - b. in the **NTP server address** field, enter the hostname or IP address the remote NTP server.
3. For the remaining underground/sea instruments, in the **NTP server address** field, enter the hostname or IP address of the underground/sea instrument that is configured for Time sharing.

4.14.2 Configuring GNSS timing

To configure GNSS timing on a TitanSMA, proceed as follows:

1. Open the Configuration menu and navigate to **Timing and Location**.
2. Select **GNSS** from the **Time source** drop-down list.
3. Select either **Duty cycled** or **Always on** from the **GNSS power mode** drop-down list.
4. Optionally, in systems where one TitanSMA must provide network timing to other instruments, select **PTP** or **NTP** from the **Time sharing** drop-down list. If selecting **PTP**, be aware that only instruments on the same subnet as this TitanSMA will be able to receive the multicast PTP messages.
5. To save the configuration, click the **Apply** button, then click the **Commit** button.

4.14.3 Configuring PTP timing

To configure the TitanSMA to receive PTP network timing from another instrument, proceed as follows:

1. Open the Configuration menu and navigate to **Timing and Location**.
2. Select **PTP** from the **Time source** drop-down list. Be sure there is at least one other Nanometrics instrument on the same subnet that is configured to act as a PTP server.
3. Optionally, in systems where one TitanSMA must provide network timing to other instruments, select **PTP** or **NTP** from the **Time sharing** drop-down list. If selecting **PTP**, be aware that only instruments on the same subnet as this TitanSMA will be able to receive the multicast PTP messages.
4. To save the configuration, click the **Apply** button, then click the **Commit** button.

4.14.4 Guidelines for selecting an NTP server

When an instrument is running as an NTP Client, the accuracy of the instrument timing is affected by the quality of communications with the NTP Server and the accuracy of the NTP Server time.

Use the following recommended order of preference when selecting an NTP Server:

1. Local stratum 1 server
2. Local stratum 1 server on a Nanometrics instrument. See [Enabling a stratum NTP server](#).
3. Local stratum 2+ server
4. Local stratum 2+ server on a Nanometrics instrument. See [Enabling a stratum 2+ NTP server](#).
5. Remote stratum 1 server
6. Remote stratum 2+ server

4.14.5 Configuring NTP timing on a TitanSMA

To configure the TitanSMA to receive NTP timing from another instrument or any other NTP server, proceed as follows:

1. Open the Configuration menu and navigate to **Timing and Location**.
2. Select **NTP** from the **Time source** drop-down list.
3. In the **NTP server address** field, enter the hostname or IP address of the desired NTP server (which may be another TitanSMA or other Nanometrics instrument). By default, the NTP server address is set to `pool.ntp.org`. This will automatically select a server based on geographical location determined by the source IP address.
If you have selected another Nanometrics instrument as the NTP server, be sure that the other instrument is configured to act as an NTP server.
4. Optionally, in systems where one TitanSMA must provide network timing to other instruments, select **PTP** or **NTP** from the **Time sharing** drop-down list. If selecting **PTP**, be aware that only instruments on the same subnet as this TitanSMA will be able to receive the multicast PTP messages.
5. To save the configuration, click the **Apply** button, then click the **Commit** button.

4.14.6 Enabling a stratum 1 NTP server on a TitanSMA



To increase the security of your network and to significantly reduce the risk of unauthorized access to your TitanSMA, we recommend that you change all default passwords after you have logged on for the first time. See [About Passwords](#).

A stratum 1 NTP server derives time directly from a radio clock or some other highly accurate time source and then serves NTP time to network connected clients. In the case of Nanometrics instruments, GNSS is used as a highly accurate time source. To enable a stratum 1 NTP Server on an instrument, proceed as follows:

1. Open the Configuration menu and navigate to **Timing and Location**.
2. Select **GNSS** from the **Time source** drop-down list.
3. To configure the best possible timing, select **Always on** from the **GNSS power mode** drop-down list.
4. Select **NTP** from the **Time sharing** drop-down list.
5. To save the configuration, click the **Apply** button, then click the **Commit** button.

When configuring another instrument as an NTP Client to connect to this instrument's NTP server use the server instrument's IP address or name as provided by the network's DNS.

4.14.7 Enabling a stratum 2+ NTP server on a TitanSMA



To increase the security of your network and to significantly reduce the risk of unauthorized access to your TitanSMA, we recommend that you change all default passwords after you have logged on for the first time. See [About Passwords](#).

A stratum 2+ server uses NTP as a time source and then serves NTP time to network-connected clients. To enable a stratum 2+ NTP Server on an instrument, proceed as follows:

1. Open the Configuration menu and navigate to **Timing and Location**.
2. Select **NTP** from the **Time source** drop-down list.
3. In the **NTP server address** field, enter the hostname or IP address of the NTP server from which this TitanSMA is to get its timing.
4. Select **NTP** from the **Time sharing** drop-down list to enable this TitanSMA to act as an NTP server for other instruments.
5. To save the configuration, click the **Apply** button, then click the **Commit** button.

When configuring another instrument as an NTP Client to connect to this instrument's NTP server use the server instrument's IP address or name as provided by the network's DNS.

4.14.8 Timing Configuration Parameters

This section describes the available parameters for configuring a timing source. You can access these parameters from **Timing and Location** in the Configuration menu.

Time source

Select the source for internal timing from the drop-down.

- **GNSS** - Select this option if absolute time accuracy is important and if the instrument's GNSS/GPS antenna has a view of the sky. It is not suitable for indoor, underground or under-water installation unless a GNSS or GPS re-radiator device is used to broadcast GNSS signals near the instrument.
- **PTP** - Select this option if absolute time accuracy is important, the instrument does not have GNSS access, and there is at least one other TitanSMA on the same subnet that is configured to act as a PTP server.
- **NTP** - Select this option to connect to a local NTP server (such as a TitanSMA or other Nanometrics instrument configured to act as an NTP server), or to an Internet NTP server.
- **Free running** - Select this option to allow the instrument to run at the accuracy of the internal oscillator. This option allows you to manually set the instrument time and to manually reset the time at intervals.

If the instrument has a GNSS receiver, the default setting is GNSS, otherwise, the default setting is PTP.

GNSS power mode

Select the power mode for the GNSS receiver.

- **Duty cycled** – Select this option from the drop-down to configure the GNSS to duty cycle automatically. In this instance, the GNSS receiver is switched on until the fine lock is reached in the system clock and then switched off until the estimated time uncertainty approaches 100 μ s (500 μ s if the temperature drops below -35°C). This is the most efficient setting for power consumption.



If the GNSS is configured to **Duty cycled** the **Health** page will indicate a time error if the modelled uncertainty exceeds 1000 μs .

Typical duty cycling on-time is 10%. However, it may be more frequent in environments with rapidly changing temperatures or with a poor GNSS satellite signal.

When in **Duty cycled** mode, if the GNSS receiver does not lock after 15 minutes of turning on, it will turn off for 135 minutes before trying again. This is to avoid consuming more power than usual if the GNSS cannot lock due to the antenna being temporarily obscured, or if the temperature is outside the operating range.

- Always on – The GNSS is always on. This mode uses more power than Duty cycled, however it provides the most accurate timing.



If the GNSS is configured to **Always on** the **Health** page will indicate a time error if the modelled uncertainty exceeds 1000 μs .

NTP server address

Enter the hostname or IP address of the NTP server with which the TitanSMA time may be synchronized. Use this option in the following situations:

- to synchronize system time when the **Time Source** is set to **NTP**
- to automatically set time on startup if **Set time using NTP on startup** is enabled and if the **Time source** is set to **Free running**
- to manually set time when the **Time source** is set to **Free running** by clicking the **Set time using NTP** button on the Maintenance page

Set time using NTP on startup

If the **Time source** is Free running, check this option to enable the system time to synchronize with the configured NTP server when the TitanSMA starts up. If this option is selected, enter a value in the **NTP server address** field.

Time sharing

Select PTP or NTP from the drop-down to configure this device to be the time source for other devices in the network. Disabled indicates that this device is not acting as a time source.

4.15 Location Configuration

The geographical location of an instrument is determined automatically by GNSS or by configuring the location manually. In the following examples are examples in which it may be useful to manually configure the geographic location:

- GNSS coverage is unavailable and therefore the TitanSMA cannot determine its own location.
- The instrument's GNSS antenna is obscured or not attached; therefore the instrument cannot determine its own location.
- The GNSS or GPS antenna is located far enough from the instrument to warrant a separate location indicator.
- Your application requires that the geographical location of the TitanSMA remains fixed, for example if you are using the TitanSMA's location as an instrument or channel identifier. GNSS-derived locations vary slightly with time.

If a geo-location is manually configured by the user, it is displayed on the Web Interface, and also used as the geo-location in any Dataless SEED response files that are created by the TitanSMA.

This section describes the parameters for configuring the geographical location of your TitanSMA. You can access these parameters from **Timing and Location** in the Configuration menu. Once configured, these values are displayed in the **User-defined Location** area on the **Health** page.

Latitude [deg]

Use this option to specify an exact location for the TitanSMA if you do not wish to use the location determined by the GNSS time source or if GNSS is unavailable. Keep the following in mind:

- Specify the location in decimal degrees.
- Enter a positive value to indicate North.
- Enter a negative value to indicate South.
- If you specify the latitude for the instrument, you must also specify longitude and elevation.

Longitude [deg]

Use this option to specify an exact location for the TitanSMA if you do not wish to use the location determined by the GNSS time source or if GNSS is not available. Keep the following in mind:

- Specify the location in decimal degrees.
- Enter a positive value to indicate East.
- Enter a negative value to indicate West.
- If you specify the longitude for the instrument, you must also specify latitude and elevation.

Elevation [m]

Use this option to specify an exact location for the TitanSMA if you do not wish to use the location determined by the GNSS time source or if GNSS. Keep the following in mind:

- Specify the elevation in metres.
- If you specify the elevation for the instrument, you must also specify latitude and longitude.

5.0 Monitor the Status Indicator LEDs

The TitanSMA has the following status indicator LEDs that you can use to monitor the current status of the instrument and troubleshoot any problems that may occur.

External LEDs:

- [Overall Status](#)
- [Power](#)
- [Link](#)
- [Time](#)
- [Media](#)
- [Event](#)

Internal LEDs:

- [Media Eject](#)
- [USB Eject](#)

5.1 Power LED

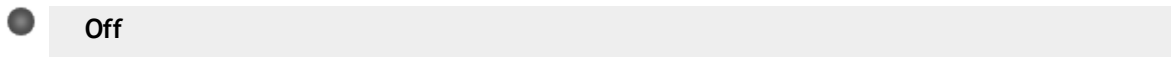

The TitanSMA has no power.



The TitanSMA is starting up (reverse sequence when shutting down).

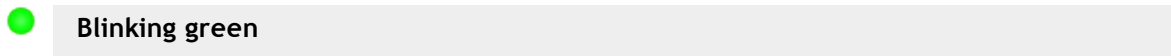

The TitanSMA has power.

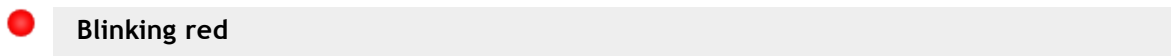

The [Force Power On](#) button was pressed to force the TitanSMA to bypass the power supply threshold settings and power up.

Once the **Force Power On** button is pressed, the Power LED will change from solid red to blinking orange and then to blinking red.

5.2 Link LED

 **Off**

No Ethernet cable is connected.

-OR-

The unit is powered off.

 **Solid green**

Link established over the Ethernet cable, but there is no activity over the Ethernet link.

 **Blinking green**

Link established over the Ethernet cable and data is being transmitted or received over the Ethernet link.

 **Solid green with orange / red flicker**

Instrument is booting, link established over the Ethernet cable and data is being received.

5.3 Time LED

 **Off**

The TitanSMA is powered off.

 **Blinking orange**

The timing system is initializing and attempting to acquire a lock to the time source. It will attempt to acquire a lock after the TitanSMA powers up.

 **Blinking green**

The TitanSMA has synchronized to an accurate time.

 **Blinking red**

The timing system is unable to synchronize to the time source. See [SOH Time statuses](#) for details of potential errors.

5.4 Media LED

 **Off**

For more information, see [Events Data Archive](#) and [Continuous Data Archive](#).

 **Blinking orange**

Checking the status of the SD card.

-OR-

The unit is in a transitional state as data archiving starts up or shuts down.

 **Blinking green**

The SD card is archiving data/ready to archive data.

 **Blinking red**

The [SD card is corrupt, full](#) or there is an error writing to the SD card, and data archiving is enabled, or the card is being repaired or formatted, or is missing.

For more information, see [Events Data Archive](#) and [Continuous Data Archive](#).

5.5 Event LED

 **Off**

No events recorded.

-OR-

No SD card detected.

 **Solid green**

Checking SD card for events.

 **Blinking green**

At least one event has been recorded to the SD card.

-OR-

5.6 Overall Status LED

 **Off**

The TitanSMA is powered off.

 **Solid red**

Initial power-on.

 **Blinking orange**

The TitanSMA is starting up and checking all of the internal systems.

 **Blinking green**

The TitanSMA is operating properly.

 **Blinking red**

There is a fault or condition that prevents the TitanSMA from operating properly. If none of the other LEDs indicate an error condition, check the [Health](#) page to determine the possible cause.

Possible problems could include the following:

- The GNSS receiver is not locked or the GNSS antenna is disconnected or shorted.
- The Data Archiving feature is enabled but the SD card is missing, full, corrupt, or could not be prepared for use.
- Configuration changes have not been committed.

- The firmware status is not okay.
- The [status](#) of the **internal storage**¹ is not okay.

-OR-

The [Force Power On](#) button was pressed to force the TitanSMA to bypass the power supply threshold settings and power up. Once the **Force Power On** button is pressed, the Power LED will change from solid red to blinking orange and then to blinking red.

5.7 USB Eject LED



The USB port is not currently supported for the TitanSMA for data archiving.

 Off

No USB device is detected.

 **Blinking red**

The USB device has been inserted and it is being prepared for use.

-OR-

The button next to the USB device has been pushed and the device is being prepared for safe removal.

The TitanSMA will attempt to prepare the USB device for safe removal. If files are still being archived to the device after 2 minutes, the USB device will return to the ready for use state and the LED will turn solid red for ten minutes and then turn off. If this happens, press the eject button to try again.

-OR-

The buttons next to the SD card and the USB device have been pressed and held for more than 6 seconds and then released to initiate a safe shutdown of the TitanSMA. Both LEDs will blink red while the TitanSMA is shutting down and then go off.

¹The device writes all of the data it receives to its Primary Internal Storage. The internal storage works like a ring buffer and it wraps around when it is full and records over the oldest data.

Solid red

The USB device is ready to use or is being used and it is not safe to remove it.

It will turn from solid red to off after 10 minutes to save power.

Solid green

The button next to the USB device has been pushed, the device has been prepared for safe removal, and it is safe to remove the USB device.

If the USB device is not removed within 10 minutes after it has been prepared for safe removal and the LED turns solid green, the device will be prepared for use again and the LED will turn to blinking red.

-OR-

The USB device has been inserted and it could not be prepared for use. The device needs to be removed and replaced with another device or reformatted.

5.8 Media Eject LED



The TitanSMA automatically detects the insertion of an SD card and will start preparing it for recording.

Off

No SD card is detected.

-OR-

The SD card is ready for use or is being used for archiving so it is not safe to remove the card because data might be lost or become corrupted if removed while archiving data.

Blinking red

The SD card has been inserted and it is being prepared for use.

-OR-

The button next to the SD card has been pushed, or the Removable Media **Eject** button on the **Maintenance** page has been clicked, and the card is being prepared for safe removal. The

TitanSMA will attempt to prepare the SD card for safe removal. If files are still being archived to the SD card after 2 minutes, the SD card will return to the ready for use state and the LED will turn solid red for ten minutes and then turn off. If this happens, press the eject button to try again.

-OR-

The buttons next to the SD card and the USB device have been pressed and held for more than 6 seconds and then released to initiate a safe shutdown of the TitanSMA. Both LEDs will blink red while the TitanSMA is shutting down and then go off.

 **Solid red**

The SD card is ready to use or is being used and it is not safe to remove it.

It will turn from solid red to off after 10 minutes to save power.

 **Solid green**

The button next to the SD card has been pushed, or the Removable Media **Eject** button on the **Maintenance** page has been clicked, the card has been prepared for safe removal, and it is safe to remove the SD card. If the SD card is not removed within 10 minutes after it has been prepared for safe removal and the LED turns solid green, the card will be prepared for use again and the LED will turn to blinking red.

OR

There was an error writing to the SD card.

6.0 Using the Web Interface

Once connected and your device is configured, you can use the Web interface to

- [Monitor the status and health of your device.](#)
- [View and declare events.](#)
- [Calibrate connected sensors.](#)
- [View waveform data.](#)
- [Perform maintenance tasks.](#)

6.1 Monitor the Status and Health of Your Instrument

In addition to [monitoring the LEDs](#) of your TitanSMA, you can also monitor the overall status and health of the device by viewing near real-time information on the **Health** page. Any problems are indicated in **red**. The last time the information was updated is shown in the lower-right corner of the page.

Each section on the **Health** page shows you the current state of health and status of your TitanSMA, grouped by component.



You can quickly check the health of the device from any page by looking at the status bar at the top of the page. The first section of the status bar displays both text and an icon to show the status of the device. **Status OK** 

6.1.1 Events

Most recent

The date, and Peak Ground Acceleration (PGA), Peak Ground Velocity (PGV), and Peak Ground Displacement (PGD) of the most recent event.

Events archive

The status of the events archive and the SD card.

The possible statuses are as follows:

- Not started – The following conditions will cause the Not started status to display. Note that the SD card should not be removed while the Events archive state is Not started:

- When events data archiving is already enabled, while archiving is starting up in response to an SD card being recognized by the instrument.
- When the instrument is ready to archive to the SD card, while archiving is starting up in response to events data archiving being set to enabled.
- Briefly, when archiving stops in preparation for the format, repair or ejection of an SD card.
- Archive OK— The SD card is archiving event data or is ready to archive event data and the last event was archived successfully.
- No archive media— The SD card is missing or there is an error writing to the current SD card. Insert an unlocked SD card, [disable the archiving of event data](#), or replace or reformat the current SD card. If an SD card is present and this error occurs, the error may be caused by the SD card being write-protected. In this case remove the SD card and unlock it before reinserting the SD card.
- Archive error— The archive is corrupted or another error has occurred. Replace or reformat the current SD card.
- Archive full— The SD card is full and no more event data can be archived. Replace the current SD card or [delete some of the archived data from the card](#).
- Disabled— The TitanSMA has not been [configured to archive event data](#) to a removable SD card.

Trigger window

The window of time, in seconds, into which the [Trigger on](#) times of the channels must fall in order for those channels to be included in the same event.



Voting threshold

Each channel of the TitanSMA can cast a specified number of votes towards getting an event declared and the voting threshold is the [minimum number of total votes](#) required for it to declare an event.

You can [configure the number of votes each channel casts](#) towards getting an event declared and you can also [configure the voting threshold](#). To ensure proper event declaration, you should give zero votes to a channel that you do not want to affect the event declaration at all and a lower number of votes to channels in noisy locations.

 **Trigger detectors**

The trigger settings of Detector 1/Detector 2/Detector 3

The possible values are as follows:

- A hyphen (-) – This means that the detector is not enabled.
- A value in *g* – This is the configured threshold value.
- A value – This is the result of the configured STA/LTA ratio.

For more information on how to enable and configure detectors, see [Trigger Detectors](#).

6.1.2 Device

System – Uptime

The time elapsed since the TitanSMA last powered up.

System – Streaming rate

The combined streaming packet rate of all of the enabled streamers.

System – Enabled streamers

The total number of enabled streamers.

System – Configuration

The status of the configuration settings.

If you have applied some changes to the configuration settings but not yet committed them, this value will be **red**. If you do not commit these outstanding changes before the next time the TitanSMA restarts, these changes will be lost.

System – Firmware

The version of the active firmware.



If you see **testcode** as the value, this means that you have upgraded the firmware but not yet made it permanent by committing it. Go to the **Maintenance** page and click **Commit** in the Firmware section to commit the new firmware.

Environment – Power consumption

The amount of power consumed by the TitanSMA measured in watts.



The system current is shown in the tooltip.

Environment – Supply voltage

The voltage level being supplied to the TitanSMA by the power source.

Environment – Temperature

The internal temperature of the TitanSMA.

The internal temperature may be several degrees higher than the ambient temperature.

6.1.3 Storage

Media Card – Status

The status of the removable media card.

The possible statuses are as follows:

- Ejecting – The SD card is being prepared for safe removal from the device. (See [Remove the SD Card](#) for more information.)
- Formatting – The SD card is being erased and reformatted with a new file system to prepare the SD card for use. (See [Format SD Card](#) for more information.)
- Media error – The following conditions will cause the media error status to display. [Repair, reformat](#), or replace the current SD card:
 - The [SD card is corrupted](#).
 - There is an error writing to the SD card. This error may be caused by the SD card being write-protected. In this case remove the SD card and unlock it before reinserting the SD card.
- Media not present – The SD card is missing from the device. Please insert an SD card or disable the archiving of data (for more information, see [Events Data Archive](#) and [Continuous Data Archive](#)).

- Media OK – The SD card is archiving data or is ready to archive data.
- Mounting – The inserted SD card has been detected and is being prepared for use. (See [Insert SD Card](#) for more information.)
- Repairing – The file system on the SD card is being repaired. This status may occur automatically if the card has become corrupt or damaged. (See [Repair SD Card](#) for more information.)
- Safe to remove – The SD card has been ejected and is no longer in use. It is safe to remove from the device. Note, if the SD card has not been removed from the device within 10 minutes, the state will change to Mounting.



Media Card – Continuous archive

The status of the continuous data archive.

The possible statuses are as follows:

- Not started – The following conditions will cause the Not started status to display. Note that the SD card should not be removed while the Media Card – Continuous archive state is Not started:
 - When continuous data archiving is already enabled, while archiving is starting up in response to an SD card being recognized by the instrument.
 - When the instrument is ready to archive to the SD card, while archiving is starting up in response to continuous data archiving being set to enabled.
 - Briefly, when archiving stops in preparation for the format, repair or ejection of an SD card.
- Archive OK – The SD card is archiving data or is ready to archive data and the latest data was archived successfully.
- No archive media – The SD card is missing or there is an error writing to the current SD card. Insert an unlocked SD card, [disable the archiving of data](#), or replace or reformat the current SD card. If an SD card is present and this error occurs, the error may be caused by the SD card being write-protected. In this case remove the SD card and unlock it before reinserting the SD card.
- Archive error – The archive is corrupted or another error has occurred. Replace or reformat the current SD card.
- Archive full – The SD card is full and no more MiniSEED data can be archived. Replace the current SD card or [delete some of the archived data from the card](#).

- Disabled – The TitanSMA has not been [configured to archive data files](#) to a removable SD card.

Media Card – Contains events

Indicates if the removable SD card contains events.

Media Card – Percentage used

The percentage of the total space used of the removable media card.



The total size of the removable media card is shown in the tooltip.

Internal Storage – Status

The status of the TitanSMA's **internal storage**¹.

The possible statuses are as follows:

- Store recording – The internal storage is functioning correctly and recording data.
- Store reindexing – The index within the internal storage is being recalculated and synchronized with the actual data that is available. Reindexing may take up to 8 hours depending on how much data is in the internal storage. Data will continue to be generated during reindexing and will not be lost. You will not be able to perform any other operations that involve the internal storage until it has finished reindexing.
- Store not ready – The internal storage is not ready for recording because it is being resized, created, reformatted, or re-created.
- Not enough space – There is not enough free space in the internal memory to accommodate the intended full size of the internal storage. It will continue to operate normally with a reduced maximum capacity.
- No Store – The internal storage is corrupt or missing. Please contact Nanometrics Technical Support if you see this status.

¹The device writes all of the data it receives to its Primary Internal Storage. The internal storage works like a ring buffer and it wraps around when it is full and records over the oldest data.

- Store wrapping – The internal storage is functioning correctly and recording data but that the store has reached its maximum capacity and is now operating like a ring buffer. When this status occurs, it wraps around and records over the oldest data.

Internal Storage – Size

The size of the internal data store. This information is also displayed on the [Summary page](#). Note that this reported size will be less than the total size of the internal media since some space is reserved for logs and other system files.

Internal Storage – Recording rate

The rate that packets are being written to the internal storage.

6.1.4 Data

Sample rate

The number of samples acquired every second, in hertz, by the TitanSMA for the primary channels.

Secondary sample rate

The number of samples acquired every second, in hertz, by the TitanSMA for the [secondary channels](#) (if enabled).

Sensitivity

The overall sensitivity of the system, expressed in counts per m/s^2 .



The sensitivity value that is displayed on the **Health page** may show a slightly different value than the sensitivity value displayed in the response file. For example, on the Health page the sensitivity value $3.01E8$ cnt/(m/s) may be displayed as $2.989933E08$ in the related response file. The slightly lower value that is shown in the response file reflects the slight attenuation that is due to the output impedance of the seismometer and the input impedance of the TitanSMA. The response file will contain a response stage that represents this adjustment

Sensor Mode

The mode for the horizontal and vertical channels of the TitanSMA in g .

6.1.5 Time

Status

The status of the internal system clock used to timestamp the data produced by the instrument.

The possible statuses are as follows:

- Time Init— The instrument has just powered up and it is attempting to synchronize its time to the configured time source.
- Time OK— The timing quality of the internal system clock is accurate to within the configured specification.
- Antenna short— If GNSS is the configured time source, the GNSS receiver has detected a short in the antenna.
- No antenna— If GNSS is the configured time source, the GNSS receiver has detected that the antenna is not connected or not drawing a current.
- Time Server Unreachable— The time source is configured to PTP or NTP and a network connection to the time source cannot be made.
- Time error— The time error status will be displayed for any of the following:
 - If GNSS is the configured time source,
 - the GNSS receiver is unlocked and it is past the initialization stage (the first 10 minutes after the instrument powers up),
 - and the modelled time uncertainty exceeds 1000 μ s.
 - If PTP is the configured time source,
 - the configured PTP server is contactable and it is past the initialization stage (the first 90 seconds after the instrument powers up or reconfigured),
 - and the time uncertainty exceeds 1000 μ s.
 - If NTP is the configured time source,
 - the configured NTP server is contactable and it is past the initialization stage (the first 5 minutes after the instrument powers up or reconfigured),
 - and the time uncertainty exceeds 5000 μ s.

See also [Timing Source](#).



The instrument will check to see if there has been a time step in **UTC**¹ (the introduction of a positive leap second) under the following conditions:

- when the instrument powers up for the first time
- after the instrument has been shut down for a long period of time
- when the instrument has been synchronized to something other than GNSS and is now being synchronized to GNSS

It takes approximately 13 minutes for the instrument to make this check and the Timing status will be **red** until this check has been completed. The International Earth Rotation and Reference Systems Service makes announcements about leap seconds in [bulletins](#).

Uncertainty

An estimate of the time uncertainty of the internal system clock relative to its time source based on factors such as measurement error, clock drift, and temperature fluctuations, for example:

- If the configured time source is GNSS, PTP, or NTP and it has good time, uncertainty is a function of the measurement error between the digitizer clock and the time source.
- If the configured time source is GNSS Duty cycled (and the GNSS is in the off cycle), or if the configured time source is Free running, or if the network time source is not providing good time, the digitizer clock is allowed to drift. In this instance, uncertainty will accumulate at a rate that is a function of temperature fluctuations and the duration of the drift.

For typical time uncertainty based on different time sources, see Timing Accuracy.

GNSS Location

The fields in this section describe the GNSS-derived geographical location of the instrument including earth location and elevation, and the number of GNSS satellites used to derive the location. GNSS latitude and longitude coordinates are derived using the World Geodetic System (WGS84) reference coordinate system.

Keep the following in mind:

- If the configured **Time source** is not GNSS, the GNSS Location fields will not display.

See "Timing Source" on page 86 for configuration information.

¹Coordinated Universal Time

User-defined Location

The fields in this section describe the user-configured geographical location of the instrument using earth location and elevation.

If the location has not been configured by the user, the User-defined location fields will display "Not configured".

See "Location Configuration " on page 95 for more information.

GNSS satellites

If the configured time source is GNSS, the number of satellites used by the GNSS receiver for position and timing calculation is displayed.

When the instrument starts up, its GNSS receiver needs to lock onto the signals from a minimum of four different satellites to calculate a three-dimensional positional fix, consisting of all three of latitude, longitude, and elevation. If less than four are visible, reposition the antenna so that it has good visibility of the open sky.

Earth location

The latitude and longitude of the instrument. These values are displayed under **GNSS Location** if GNSS is the configured time source and under **User-defined Location** if Latitude, Longitude and Elevation have been configured.

Elevation

The elevation of the instrument. These values are displayed under **GNSS Location** if GNSS is the configured time source and under **User-defined Location** if Latitude, Longitude and Elevation have been configured. GNSS uses the World Geodetic System (WGS84) reference ellipsoid / datum to define elevation. With this in mind, elevation is defined as the height above ellipsoid (as opposed to height above mean sea level).

6.1.6 Alerts

The Alerts section provides you with a list of recent system-related events such as start-ups, shutdowns, and configuration changes.

6.2 Event Detection and Declaration

The channels of the TitanSMA continuously digitize time series data, which is recorded to the **internal storage**¹. You can configure the TitanSMA to stream this time series data to another device or application and/or archive it on a removable media card. You can also download it from the device using the options on the **Maintenance** page.

If you want the TitanSMA to detect and declare events in addition to continuously recording time series data, you have to enable a detector for one or more of the time series channels and assign a number of votes to all channels with enabled detectors. The TitanSMA uses the detectors combined with a voting system to declare an event. A detector is an algorithm that is applied to a channel and is based on either a configured threshold value or a configured STA/LTA ratio. As soon as the channel detector detects that the threshold value or STA/LTA ratio has been exceeded, it generates a trigger for that channel. When the TitanSMA sees this trigger, it counts how many votes are assigned to the channel that generated that trigger. If the number of votes are equal to or higher than the configured number of required votes, an event is declared with the date and time of the trigger. If not enough votes were received from the trigger, then the TitanSMA waits for additional triggers for a configured period of time to allow for transmission latency. If not enough votes are received within the configured period of time, the triggers are discarded and no event is declared. If enough votes are received, an event is declared and written to the internal storage and posted on the **Events** page. If configured, the time series data for the event is also written to a removable media card.

Event declaration can happen locally using only the channels of the TitanSMA or it can happen across a network between multiple devices if you enable the option to share triggers across a network.

You can view information about the declared events on the **Events** page, download them locally from devices in the network, and, if required, you can also manually declare an event. You can check the **Last updated** information in the lower-right corner to see the age of the data.

¹The device writes all of the data it receives to its Primary Internal Storage. The internal storage works like a ring buffer and it wraps around when it is full and records over the oldest data.

6.2.1 View and Manage Events

The **Events** page shows you the date and time of each **event**¹ recorded in the **internal storage**² as well as the peak ground motion data products, cause and source, and the number of **triggers**³ for that event. It also shows whether the event has been archived to the removable media or not. If the TitanSMA has been [configured to automatically archive events](#) to an SD card, then all declared events will be on the SD card as well as in the internal storage.

Download Archived Events

You can download locally to your computer any event that has been archived to the removable SD card. The available formats depend on the configuration for the [events data archive](#). To download archived events, select the checkboxes next to the events you want to download and then click **Download**.

The archived events are downloaded locally in a compressed file (.zip) that contains all available formats.



You cannot download events that are only stored in the internal storage on the **Events** page but you can [retrieve data](#) from the internal storage on the **Maintenance** page.

You can download events locally by navigating to the **Events** page and clicking on the **SEED** icon located in the **Download** column.

Download Events Using Secure FTP

You can log into the instrument with read-only access and download MiniSEED event data from the SD card using a secure **FTP**⁴ connection and the FTP client application of your choice.

¹Seismic activity that is detected and declared by the instrument using a voting system and threshold values or STA/LTA trigger algorithms.

²The device writes all of the data it receives to its Primary Internal Storage. The internal storage works like a ring buffer and it wraps around when it is full and records over the oldest data.

³Messages generated by the instrument when the STA/LTA ratio for one or more channels go above the configured trigger on ratio or when the configured threshold value is exceeded. Each trigger is assigned a number of votes (on the source device) that it casts towards getting an event declared.

⁴File Transfer Protocol

Once you have logged on to the instrument, you can locate MiniSEED event data in the following location on the SD card:

- /var/archive/events



The instrument must have an SD card installed and the instrument must be configured to archive data (see [Events Data Archive](#) and [Continuous Data Archive](#)) to use this feature. You have to log on to the instrument using the calibration user account (user name: calibration, password: calibrate) to download events via secure FTP.



To increase the security of your network and to significantly reduce the risk of unauthorized access to your TitanSMA, we recommend that you change all default passwords after you have logged on for the first time. See [About Passwords](#).

Delete Archived Events

You cannot delete events that are only stored in the internal storage but you can delete any events that have been archived to the removable SD card. You have two options for deleting events:

- You can select the checkboxes next to the events you want to delete and then click **Delete**.

-OR-

You can click the **Delete all event archives** button to delete all existing content on the SD card.



You have to be logged on using the admin user account to delete all of the event archives on the SD card and you have to confirm that you want to do it since this action cannot be undone.



To increase the security of your network and to significantly reduce the risk of unauthorized access to your TitanSMA, we recommend that you change all default passwords after you have logged on for the first time. See [About Passwords](#).

6.2.2 Manually Declare Events

If you know that an **event**¹ occurred but for some reason it was not declared as an event (for example, not enough votes were cast to get an event declared or the voting threshold was set too high), you can manually declare an event on the **Events** page. The manual declaration is based on the historical data stored in the **internal storage**².

You have to log on using the admin user account before you can declare an event.



To increase the security of your network and to significantly reduce the risk of unauthorized access to your TitanSMA, we recommend that you change all default passwords after you have logged on for the first time. See [About Passwords](#).

The event will appear in the list of Events on the **Events** page as soon as you click **Declare Event**. You will be able to download it and view the peak ground motion products for the event as soon as it has been successfully retrieved from the internal storage and it will also be archived on the removable SD card if the TitanSMA has been [configured to archive event data](#). The **Source** column will help you distinguish automatically declared events from any that have been declared manually (user).

6.3 About Calibration

The calibration feature allows you to input an electrical test signal into the sensor to simulate ground motion. The resulting output is measured to verify functionality, sensitivity, and/or frequency response. For a high quality instrument, these parameters typically remain stable over time, so that if the instrument initially meets manufacturer's specifications and has not suffered damage, then recalibration is not required. However, calibration can be a useful quality control check if it is suspected that the instrument may be defective or damaged after multiple deployments. In addition, if the initial sensitivity and frequency response are not within accepted parameters, it may be necessary to calibrate the instrument to supply the correct response metadata.

¹Seismic activity that is detected and declared by the instrument using a voting system and threshold values or STA/LTA trigger algorithms.

²The device writes all of the data it receives to its Primary Internal Storage. The internal storage works like a ring buffer and it wraps around when it is full and records over the oldest data.

The TitanSMA data recorder can generate and output an analog signal to be applied to the internal sensor for calibration purposes. This signal is generated by the TitanSMA playing back a pre-installed digital calibration file, containing a digital time series waveform which is fed to an internal digital-to-analog converter (DAC) and applied to the sensor. The digital calibration file can contain any desired waveform such as a sine wave, step function, random noise, or pseudo-random binary sequence (PRBS).

Calibration is launched from the **Waveform** page in the TitanSMA Web interface. A calibration file is selected and played, and the instrument output may be observed in the waveform display while it is simultaneously recorded for later analysis. See [Calibrating your instrument](#).

The following sample calibration files are supplied with the TitanSMA. These files may be used to visually verify functionality and approximate sensitivity of the instrument by inspection of the output waveform:

- The file `sine_2g_30s` generates a 1 Hz sine wave with 2 g amplitude lasting 30 seconds.
- The file `step_0g_to_2g_15s` generates a 0 g signal for 15 seconds followed by a positive 2 g step function lasting 15 seconds.

A more sophisticated measurement of frequency response may be accomplished by applying a broadband (multi-frequency) input to the instrument and analyzing the output data with suitable post-processing software. Typically, calibration software will calculate the transfer function (amplitude gain and phase shift as a function of frequency) and fit poles and zeros to generate custom response metadata for the instrument under test. The form and parameters of the input function (single pulse, PRBS, swept sine, or random noise) will depend on the requirements of the particular software used. See [Creating a custom calibration signal file](#).

6.3.1 Calibrating your instrument

Before you can calibrate your instrument, you will need a calibration signal file. You can use one of the calibration signal files that ships with your TitanSMA or you can create your own calibration signal file. See [Creating a custom calibration signal file](#).

To calibrate your instrument, proceed as follows:

1. Log on to your TitanSMA using the admin user account. See [Logging On to the Web Interface](#).



To increase the security of your network and to significantly reduce the risk of unauthorized access to your TitanSMA, we recommend that you change all default passwords after you have logged on for the first time. See [About Passwords](#).

2. Navigate to the **Waveform** page and select a file from the **Signal file** drop-down list.
3. If you want to create a calibration event while the instrument is calibrating, select the **Create event** check box. The duration of this calibration event is based on the duration of the signal file plus the pre and post-event times.
4. Click the start calibration button . Once the calibration is complete, you will be able to download the calibration event from the [Events](#) page. (A calibration event will display *Calibration @* in the **Cause @ Source** column.)



When calibration starts, a small signal offset might be generated for between 1 and 2 s, and then the first sample of the calibration signal file is driven precisely at the start of a second. That second is at least 5 s after the start calibration button has been clicked.

6.3.2 Creating a custom calibration signal file

You can create a custom calibration signal file using one of two methods:

- To manually create a custom calibration signal file, use the file format information below and any software that can export raw (headerless) audio files, such as [Audacity®](#). Once you have created the custom calibration signal file, [upload](#) it to your TitanSMA.

OR

- To create a custom calibration signal file using the provided Ruby script (<http://www.ruby-lang.org/en/>), proceed as follows:
 1. Download the script by entering the following in the browser address bar:
http://IPaddressofyourinstrumentTitanSMA/calibration/create_accelerometer_calibration_signal.rb
 2. Run the script, specifying the following parameters:
 - signal type (sine or step)
 - the duration in seconds
 - the amplitude in g
 - a name for the output file
 3. Once the custom calibration signal file has been created, [upload](#) it to your TitanSMA.



Custom calibration files with a combined maximum size of 50 MB (or approximately 14 minutes of calibration time) can be uploaded to your TitanSMA.

File Format Information

Format	Uncompressed raw
Header	None
Encoding	Signed 16-bit integer (only the most significant 14 bits are used)
Byte order	Little-endian ¹ (In this order, the bytes of a multibyte value are ordered from least significant to most significant.)
Channels	
Start offset	0 bytes
Sample rate	30 000 Hz
Output signal	The maximum output signal (-2 g) corresponds to the maximum value (32 767)

Value (2's complement)	Output signal
-32768 (0x8000)	+2 g
0 (0x0000)	0 g
32767 (0x7FFF)	-2 g

6.3.3 Uploading a custom calibration signal file

Once the custom calibration signal file has been created, you can upload it using an **SSH**²-based file transfer protocol such as **SFTP**³ or **SCP**⁴.

¹In this order, the bytes of a multibyte value are ordered from least significant to most significant.

²Secure Shell

³SSH File Transfer Protocol

⁴Secure Copy

File Transfer Protocol Information

Protocol	SFTP or SCP
Host name	IP address of your TitanSMA
Port number	22
User name	calibration
Password	calibrate (default)
Upload location	/usr/share/nanometrics/calibration



You will have to re-upload your custom calibration signal file after you upgrade the firmware of your TitanSMA because it will be overwritten during the upgrade process.

6.4 View Digitized Waveforms in Near Real Time

You can see the sensor signals being recorded by the TitanSMA in near real time by [viewing the digitized waveforms](#) on the **Waveform** page. One horizontal signal line is displayed for each channel of the TitanSMA on a data plot with a time scale.



If you attempt to view waveforms on more than two Web Interfaces at the same time, the error message "An error occurred receiving waveform data" will be displayed.

If the sensor needs to be calibrated, you can also perform a sensor calibration from this page using a calibration signal file format. See [Sensor calibration](#).

6.4.1 View Waveform Data

The **Waveform** page shows a horizontal signal line, or trace, in near-real time for each channel of the TitanSMA. To ensure that waveforms are displayed correctly, make sure that you have installed one of the following browsers: Chrome version 16 or newer, Firefox version 11 or newer, or Safari version 7 or newer.



If you attempt to view waveforms on more than two Web Interfaces at the same time, the error message "An error occurred receiving waveform data" will be displayed.

The trace is displayed with any DC offset removed, for ease of viewing when a large DC offset is present in the signal (This is for display only and does not alter the signal that is actually recorded or streamed). The traces all begin and end at the same time and the starting time is shown in the lower-left corner of the data plot with time increasing to the right. The current time scale is shown at the bottom of the data plots between the current time and the plus and minus buttons. You can click the plus and minus buttons to increase or decrease the time scale.



- Click the pause button at the bottom of the data plot or click any of the traces to pause the traces. The colour of the traces changes to **blue** when paused.
- Click the rewind or fast forward button or click and drag the cursor on a trace to move back and forward in time. The amount of data buffered will limit how far back in time you can go.
- The **SCNL**¹ and sample rate is shown in the upper-left corner of each trace plot as well as the mean, **RMS**, minimum, and maximum. You can use the mean value to configure the [Channel offset setting](#).

6.5 Perform Maintenance Tasks

From time to time, you might have to perform simple maintenance tasks to ensure that your TitanSMA continues to operate correctly. These tasks include manually setting instrument time, upgrading the firmware, and retrieving time series, SOH, or response files from the TitanSMA's **internal storage**² or archives on the SD card. You can perform these tasks on the **Maintenance** page as well as download log files, format or repair the SD card, restart/shut down the TitanSMA, and reindex or re-create the TitanSMA's internal storage.

You have to be logged in with the admin user account to perform any of the tasks on the **Maintenance** page.



To increase the security of your network and to significantly reduce the risk of unauthorized access to your TitanSMA, we recommend that you change all default passwords after you have logged on for the first time. See [About Passwords](#).

¹Station, Channel, Network, Location names

²The device writes all of the data it receives to its Primary Internal Storage. The internal storage works like a ring buffer and it wraps around when it is full and records over the oldest data.



You should only click **Shutdown** on the Maintenance page if you are in the same location as the TitanSMA because it is not possible to power it up remotely.

6.5.1 Setting Instrument Time

If the configured Time source is Free running, you can manually set the instrument time to a given value or do a one-time synchronization of the TitanSMA time to a configured NTP server.

To manually set the instrument time:

1. Access the Web Interface for your TitanSMA and navigate to the **Instrument Time** section on the **Maintenance** page.
2. Enter the date (yyyy-mm-dd) and time (hh:mm:ss)
3. Click the **Set time** button. The instrument time will be synchronized to the configured date and time. The instrument time will then free-run.

To set the instrument time by synchronizing to a configured NTP server:

1. Access the Web Interface for your TitanSMA and open the **Configuration** dialog box.
2. Select **Timing and Location** from the left pane. Make sure that **NTP server address** is configured.
3. On the Web Interface, navigate to the **Maintenance** page, **Instrument Time** section.
4. Click the **Set time using NTP** button. The instrument time will be set by synchronizing it once to the configured NTP server. The instrument time will then free-run.

See "Timing Source" on page 86 for information about configuring timing.

6.5.2 Upgrade Firmware



Before you upgrade the firmware on your TitanSMA, refer to the release notes for the specific firmware version for recommendations and special considerations.



The **Delete** button on the **Maintenance** page is used to delete the firmware installation package. The actual firmware will not be deleted. If a firmware installation package does not exist on internal storage, then the **Delete** button is disabled.

To upgrade your firmware, follow the procedure below:

1. Contact Nanometrics Technical Support to obtain the latest firmware upgrade package (.tgz file) and download it to your computer.
2. Access the Web Interface for your TitanSMA and navigate to the Firmware section on the **Maintenance** page.
3. If required, click the **Commit** button to make the active firmware permanent.



If the currently loaded firmware has already been committed the **Commit** button is disabled. You can also verify if the firmware is committed from the Device section on the **Health** page.

4. If the **Available Firmware** field displays the version number of a previously uploaded installation package, click the **Delete** button to remove the installation package from your TitanSMA. If no installation package is present, the **Available Firmware** list is disabled.



Only one installation package can be present on the TitanSMA. The previous version must be deleted before you can upload the latest firmware installation package.



Deleting a previously uploaded firmware installation package will not affect the operation of your TitanSMA.

5. Upload and commit the latest firmware to your TitanSMA:
 - a. Click the **Choose file** button to select the new firmware installation package to upload to the TitanSMA.
 - b. Click the **Upload** button. A message will be displayed if the upload is successful.
 - c. Click the **OK** button to confirm the upload and select the release from the **Available firmware** list.
 - d. Click the **Apply** button to temporarily install the firmware. Your upgrade must be applied before it can be committed. The progress of the installation is shown in the installation log.



This operation will take several minutes. The TitanSMA will restart automatically after it has completed installing the firmware. You should not navigate away from the **Maintenance** page until the TitanSMA has completed installing the firmware and the device has restarted.

- e. After the TitanSMA has restarted, navigate to the Firmware section on the **Maintenance** page and click the **Commit** button to ensure the newly upgraded firmware is installed.

6. The installation package is no longer required once the firmware has been committed to the TitanSMA. Click the **Delete** button to remove the firmware installation package from your TitanSMA.



Deleting the firmware installation package will not affect the operation of your TitanSMA.

6.5.3 Retrieve Data from the Internal Storage

In addition to streaming data from the TitanSMA to a network device and archiving data to the removable SD card, you can also retrieve time series and SOH data directly from the TitanSMA's **internal storage**¹ by downloading it from the **Maintenance** page to your computer.

When you specify the date and time range of the retrieval, remember that the internal storage wraps around when it is full and records over the oldest data. The frequency with which the internal storage wraps is shown in the [Internal Storage section](#) on the **Health Page**.



Only one data retrieval request can be run from one TitanSMA at any time. Any subsequent retrieval requests will be processed when the current download has finished.

SOH floating point values, such as Sensor SOH Voltage, External SOH Voltage, Supply Voltage and Total Current that are included in downloaded data files are recorded with more digits of precision than necessary and do not reflect the actual precision of the measurement.

Retrieving MiniSEED Data from the Internal Storage

MiniSEED records that are downloaded from the **Maintenance** page within a single MiniSEED file are sequenced with a 6-digit number. Once this 1 million record limitation is reached, the numbering sequence will start over resulting in non-unique record numbers. Some tools may not be able to open a single file that contains more than 1 million records. Once you have selected which MiniSEED data to retrieve from internal storage, the TitanSMA will display an error message if it determines that the data retrieval request may exceed 1 million records.

Use the following recommendations to configure a data request that will download fewer than 1 million MiniSEED records in one file:

¹The device writes all of the data it receives to its Primary Internal Storage. The internal storage works like a ring buffer and it wraps around when it is full and records over the oldest data.

- Choose a different **Data file length** (One file is recommended)
- Select fewer channels for a data retrieval download
- Decrease the **Time range** for data retrieval

The error message will disappear once the number of requested MiniSEED records falls below 1 million. Click on the **Download** button to retrieve the requested data.

6.5.4 Download Log Files

If required for troubleshooting purposes, you can view the system logs for your TitanSMA by clicking **Log files** in the **Download files** section on the **Maintenance** page. Once the log file is displayed, typically, you can save the system log as a *.txt file by right-clicking anywhere on the window. Note that this method is available if you use Nanometrics-recommended browsers. Other browsers may use a different method for saving.

6.5.5 Download Archive Files

If an SD card is present and configured to archive continuous and/or event data, and SOH data, you can periodically download archive files.

From the **Maintenance** page, in the **Download Files** section, click **Archive files**.

The archive opens in a separate tab in your browser where you can select the files you wish to download.



The **.store** directory on the SD card is the file system reserved by the TitanSMA for backup storage. Do not delete the **.store** directory or modify files within the directory. The best way to protect your data is to [configure continuous archiving](#) to your SD card. For more information, see [About Data Storage](#).

Continuous data are stored in directories labelled by date. Event data are contained in the **events** directory. If you have enabled SOH in either or both continuous and event archives, you will see an **soh** subdirectory in these archives.



Archive files can only be downloaded one file at a time using this method. As an alternative, you can download multiple files using secure FTP and an FTP client of your choice.

Unexpected Data in Archive Files

An unexpected power cut may cause a small amount of garbage data (approximately 32 kB) to be added to an archive file that is being written at the time of the power cut. This garbage data may appear as a series of '0's. If the SD archive media has been used previously, the data may appear as random values.

This irrelevant garbage data may affect the readability of the resulting archive file by some software tools.

6.5.6 Download Channel Response Files

Use SEED response files to access the transfer function response information for your instrument. These response files describe the signal input/output response of a sensor and a digitizer in accordance with the SEED format version 2.4 (https://www.fdsn.org/media/_s/publications/SEEDManual_V2.4.pdf). SEED response information can be retrieved in either native dataless SEED format or RESP format (readable text).

You can download response files from the following locations:

- For the current instrument configuration directly from your TitanSMA:
 - on the **Maintenance** page as described below, or
 - using the [Instrument Response API](#).
- For a set of standard configurations:
 - From Nanometrics' customer support site at <http://support.nanometrics.ca>.
 - From the IRIS DMC Library of Nominal Responses for Seismic Instruments at <http://d-s.iris.edu/NRL/>.

To download channel response data directly from the instrument:

1. From the **Maintenance** page, in the **Channel Response** section, select the desired file format from the **Choose response file format** drop down list.
2. Click the **Download** button. A zip file containing one response file for each channel will be downloaded to your browser's download location.

You can also use the [Instrument response API](#) to download overall instrument response.

Note that response files that are downloaded from the TitanSMA reflect the configuration of the TitanSMA at the that time the download is initiated, including SCNL, geo-location, and the response of both the digitizer and the accelerometer within the TitanSMA. The **Start-time** field is

filled in with the time that the response creation request was made and the **End-time** field remains blank. Geo-location is included in the Dataless SEED format but not the RESP format, and uses the manually-configured geo-location if configured, otherwise the GNSS-derived geo-location if available.

6.5.7 Removable Media

The **Removable Media** section on the **Maintenance** page provides:

- information about the [status](#) and the percentage of memory used on your SD card.
- the ability to remotely re-format your SD card in FAT32 format.
- a repair function that runs a file system check on your SD card.



Nanometrics recommends that you attempt to Repair your SD card before attempting to reformat it. The Format SD Card option should be used as a last resort as any previously saved data will be deleted from the SD card when the card is reformatted.

Format SD Card

Format your SD card by selecting FAT32 and clicking **Format** on the **Maintenance** page. Any data on your SD card is permanently deleted and a new file system is set up for reading and writing data.

Repair SD Card

When you repair your SD card by clicking the **Repair** button on the **Maintenance** page, TitanSMA runs a file system check on your SD card and repairs the file system, if possible.

6.5.8 Perform Maintenance on the Internal Storage

Typically, you only need to perform internal storage maintenance tasks when instructed to do so by Nanometrics Technical Support for troubleshooting purposes. These tasks involve using Internal Storage Tools on the **Maintenance** page to reindex or re-create the data Store, which is located in internal storage media. For more information about internal storage, see [About Data Storage](#).

Reindexing the Store

To reindex the Store, which is located on the internal storage media, click **Reindex** on the **Maintenance** page. The index within the Store is recalculated and synchronized with the actual

data that is available. Reindexing might take a long time depending on how much data is in the Store. Data will continue to be generated during reindexing and will not be lost.

Re-creating the Store

To re-create the Store, click **Re-create** on the **Maintenance** page. All data in the Store is permanently deleted and a new Store is created.

In the event of internal storage failure

In the event of internal storage failure, the Status LED flashes red on the instrument and there will be a warning message on the **Health** page indicating that data is being written to a temporary location in RAM.

The backup Store in RAM is primarily used to backfill a limited amount of data lost during network outages for deployments using continuous streaming.

Any configured streamers are unaffected by internal storage failure.

What should I do?

- Contact Nanometrics Technical Support. Support staff will instruct you about your next steps, which may involve [re-indexing or re-creating](#) the Store, or replacing your flash storage media.

6.5.9 Restart/Shut Down a TitanSMA

Read the information in this topic carefully before you shut down or restart your TitanSMA from the **Maintenance** page.

Shut Down a TitanSMA



You should only click **Shutdown** on the Maintenance page if you are in the same location as the TitanSMA because it is not possible to power it up remotely.

Before initiating a system shut down, navigate to the **Health** page to verify the [Internal Storage – Status](#). Initiating a system shutdown while the Store is being recreated can result in the Store being corrupted. If the Store has become corrupted, delete the Store and restart the TitanSMA to allow normal operation. Contact techsupport@nanometrics.ca for instructions on deleting the Store.

You should shut down a TitanSMA before you disconnect the power to avoid the possibility of a lengthy [reindexing](#) of the internal storage on restart. You can do this by clicking **Shutdown** on the [Maintenance Page](#) or by pressing and holding the USB and SD card buttons behind the media bay door and waiting until both the USB LED and the SD LED have turned off.

When you click **Shutdown**, all data files are closed and saved and the Web server is shut down so that no data is lost when the power is disconnected. You can disconnect the power to the TitanSMA when all of the LEDs on the case have turned off.

Restart a TitanSMA

In general, you should only click **Restart** on the Maintenance page if instructed to do so by a Nanometrics representative for troubleshooting purposes. Recording and communications will be interrupted while the TitanSMA is restarting.

7.0 Application Program Interfaces (APIs)

The following HTTP-based APIs are available for the TitanSMA.

- [Data Availability API](#)
- [FDSN-WS Data Retrieval API](#)
- [Nanometrics Data Retrieval API](#)
- [State of Health API](#)
- [Instrument Response API](#)

Syntax

- Unless indicated otherwise, the APIs use HTTP GET requests to retrieve information.
- Requests consist of a base URI followed by a set of zero or more parameters. The first parameter in the set is prefixed with "?". Each subsequent parameter is prefixed with "&".
Format: baseURI?first_parameter&next_parameter&next_parameter&...
Example using 2 parameters: /api/v1/bands/availability?dataSource=titanSMA__0007&type=timeseries
- Unless indicated otherwise, all parameters are optional. Optional values are given in the format {a|b}. The curly braces and vertical bar indicate the options and are not part of the API request.
- Note that APIs where all parameters are optional require the use of at least one parameter to return data.
- The use of *bold-italics* indicates the default value of an optional parameter.

7.1 Data Availability API

The Data Availability API provides the means for custom scripts and applications to retrieve data availability information from TitanSMA. Requested data is defined by selecting a base URI to determine the data source (band or channel). The data is further defined by selecting data source, data type and time option parameters. The response data is provided in JSON format and indicates ranges of time for which contiguous data is available on the instrument's primary, internal media.

BASE URIs

Use the following URI to return data from a device using the [bandId/instrumentID](#) parameter.

```
/api/v1/bands/availability.json
```

Use the following URI to return data from a device using the [channels](#) parameter.

```
/api/v1/channels/availability.json
```



.json is part of the base URIs. If you specify any parameters, you must remove .json from the API request.

Parameters

type

Use this parameter to specify data type.

Format: type={**all**|soh|timeSeries}

Select

- **all** to return all data types.
- **soh** to return only State of Health data.
- **timeSeries** to return only timeSeries data.

Example snippet: type=all

bandId/instrumentID

Use this parameter to specify a band or instrument data source.

Format1: bandId=instrumentId_SN/band/timeSeries1

Example snippet: /api/v1/bands/availability?bandId=titanSMA__0107/band/timeSeries...

Format2: dataSource={instrumentId_SN|NX.STN}

Example snippet: /api/v1/bands/availability?dataSource=titanSMA__0007&type=timeseries...

Notes:

- Network.Station format only works with SEEDLink bands.
- Binder lookups are not performed.
- Multiple bandId parameters or instrumentID parameters are permitted.

channels

Use this parameter to specify a channel data source. Note that a binder is required.

Format: `channels={NX.STN.*}`

Example snippet:

```
/api/v1/channels/availability?channels=XX.*.*.*&type=timeseries...
```

Notes:

- Uses channel naming configuration in internal Binder.
- If this parameter is omitted, information for all available channels is returned.
- SOH channels return a modifier on the end of the channel name to differentiate between potentially different data that is available for different SOH types.
- Refer to “Channel list” in the Apollo Server User Guide for the format for specifying SCNL elements in a filter.

view

Use this parameter to trim returned data.

Format: `view=trimmed`

Example snippet: `view=trimmed`

Notes:

- Time ranges are trimmed to the time defined by the [Time](#) parameter.
- Sequence numbers are removed.

Time

Use this parameter to specify the ISO8601 time option.

Format: `{start|end}Time=yyyy-MM-ddTHH:mm:ss.sssZ`

Select:

- `start` to define the start time for retrieving data using the ISO8601 standard.
- `end` to define the end time for retrieving data using the ISO8601 standard.

Example snippet: `startTime=yyyy-MM-ddTHH:mm:ss.sssZ`

Notes:

- Milliseconds (.sss) are optional.
- Time is expressed in accordance with the ISO8601 standard.
- The Z indicates UTC (Zulu) time zone, non-UTC time zones are not supported.
- If you do not specify an end time, then it is assumed that the end time is the current time.

Millis

Use this parameter to specify the Milliseconds time option.

Format: {start|end}Millis=#####

Select:

- `start` to define the start time for retrieving data in Milliseconds.
- `end` to define the end time for retrieving data in Milliseconds.

Example snippet: `startMillis=1371686400000&endMillis=1371772800000`

Notes:

- Since 1970
- If you do not specify an end time, then it is assumed that the end time is the current time.

Nanos

Use this parameter to specify the Nanoseconds time option.

Format: {start|end}Nanos=#####

Select:

- `start` to define the start time for retrieving data in Nanoseconds.
- `end` to define the end time for retrieving data in Nanoseconds.

Example snippet: `startNanos=1371686400000000000&endNanos=1371772800000000000`

Notes:

- Since 1970
- If you do not specify an end time, then it is assumed that the end time is the current time.

Examples

This section provides examples of requests. Availability information for the requested data source and time period (or all if unspecified) is returned. The date and time in the returned data is in ISO8601 format, including nanoseconds. For instance, the combined date and time format is 2013-06-25T10:32.26.000000000Z.

Note that "ranges" in output indicate gaps in the data. Several ranges in an output could indicate a problem.

bandId/instrumentId

```
http://10.10.10.10/api/v1/bands/availability?type=timeseries&startTime=2013-06-21T12:00:00.000Z
```

```
http://10.10.10.10/api/v1/bands/availability?dataSource=titanSMA__0007&type=timeseries&startTime=2013-06-21T00:00:00Z
```

```
http://10.10.10.10/api/v1/bands/availability?dataSource=titanSMA__0007&type=timeseries&startMillis=1371686400000&endMillis=1371772800000
```

Trimmed example of the JSON data returned for bandId/instrumentId (... indicates where the data would continue)

```
{
  "availability": [
    {
      "id": "titanSMA_0069/band/timeSeries1", "ranges": [
        {
          "startTime": "2013-06-18T17:03:31.180000000Z",
          "endTime": "2013-06-19T15:01:44.035000000Z"
        },
        {
          "startTime": "2013-06-19T15:01:59.350000000Z",
          "endTime": "2013-06-19T22:27:50.760000000Z"
        }
      ]
    },
    {
      "id": "titanSMA_0069/band/timeSeries2", "ranges": [
        ...
      ]
    }
  ]
}
```

channels

<http://10.10.10.10/api/v1/channels/availability?type=timeseries&startTime=2013-06-21T12:00:00.000Z>

http://10.10.10.10/api/v1/channels/availability?channels=XX.*.*&type=timeseries&startTime=2013-06-21T00:00:00Z

http://10.10.10.10/api/v1/channels/availability?channels=!XX.*.*&type=timeseries&startTime=1371686400000&endTime=1371772800000

Trimmed example of the JSON data returned for channels (... indicates where the data would continue)

```
{
  "availability": [
    {
      "id": "CI.ADO/BHZ", "ranges": [
        {
          "startTime": "2013-06-18T17:03:31.180000000Z",
          "endTime": "2013-06-19T15:01:44.035000000Z"
        },
        {
          "startTime": "2013-06-19T15:01:59.350000000Z",
          "endTime": "2013-06-19T22:27:50.760000000Z"
        }
      ]
    },
    {
      "id": "CI.ADO/BHN", "ranges": [
        ...
      ]
    }
  ]
}
```

7.2 Web Service data download interface (FDSN-WS)

This web service interface allows you to download recorded time series sensor data and SOH data in MiniSEED format. The API is compliant with FDSN-WS Specifications version 1.1. See <http://www.fdsn.org/webservices/FDSN-WS-Specifications-1.1.pdf> for complete details.

The *fdsnws-dataselect* service currently supports the following methods:

- *query*
- *version*
- *application.wadl*

The following required parameters of *fdsnws-dataselect* service are supported:

- *starttime*
- *endtime*
- *network*

- *station*
- *location*
- *channel*

The following optional parameters are not supported at this time.

- *quality*
- *minimumlength*
- *longestonly*
- *format*
- *nodata*

Example snippet:

```
/fdsnws/dataselect/1/query?network=XX&station=S0001&location=*&channel=ZZ  
Z&starttime=2015-05-20T18:21:00.000&endtime=2015-05-20T18:22:00.000
```

7.3 Nanometrics data retrieval API

This API allows you to download recorded sensor data or SOH data from a TitanSMA.



This API has been deprecated. We recommend that you use the [FDSN-WS Data Retrieval API](#).

BASE URI

```
/retrieval
```

Parameters

Group

Use this parameter to select either digitized time-series data or SOH data to download.

Format: Group={TIME_SERIES|SOH}

Select:

- **TIME_SERIES** to download digitized time-series data.
- **SOH** to download State-of-Health data.

Example snippet: Group=TIME_SERIES

Notes:

- The `TIME_SERIES` option is required if you wish to use the [TIME_SERIES \[n\]](#) parameter.
- The `SOH` option is required if you wish to use the [ENVIRONMENT](#), [TIMING](#), or [TRIGGER](#) parameters.

TIME_SERIES_[n]

Use this sub-parameter to select time series data if you have specified the `TIME_SERIES` [group](#).

Format: `TIME_SERIES_[n]=true`; where n=the channel number

Select `true` to download time series data for the defined channel.

Example snippet: `TIME_SERIES_1=true&TIME_SERIES_2=true&TIME_SERIES_3=true`

Notes:

- You can only use this parameter if you have specified the `TIME_SERIES` group.
- At least one channel must be defined. If you do not define a channel an HTTP 500 error stating that "no channels were selected" will result.
- One or more channels may be included in each request.
- The available channels are TimeSeries1/2/3, 1/2/3/101/102/103 with secondary channels enabled.
- The SCNL information included in the MiniSEED file is defined in the [Channel Naming](#) section.

ENVIRONMENT

Use this sub-parameter to retrieve environment SOH data if you have specified the `SOH` [group](#).

Format: `ENVIRONMENT=true`

Select `true` to download environment SOH data for the defined time range.

Example snippet: `ENVIRONMENT=true`

Notes:

- You can only use this parameter if you have specified the `SOH` group.
- This parameter can be called with the [TIMING](#) and [TRIGGER](#) parameters.
- Several SOH groups may be selected and multiple groups can be downloaded in a single request.
- Refer to [SOH Groups](#) for a listing of the data available for each SOH group.

TIMING

Use this sub-parameter to retrieve timing SOH data if you have specified the SOH [group](#).

Format: TIMING=true

Select `true` to download timing SOH data for the defined time range.

Example snippet: TIMING=true

Notes:

- You can only use this parameter if you have specified the SOH group.
- This parameter can be called with the [ENVIRONMENT](#) and [TRIGGER](#) parameters.
- Several SOH groups may be selected and multiple groups can be downloaded in a single request.
- Refer to [SOH Groups](#) for a listing of the data available for each SOH group.

TRIGGERS

Use this sub-parameter to retrieve environment SOH data if you have specified the SOH [group](#).

Format: TRIGGERS=true

Select `true` to download trigger SOH data for the defined time range.

Example snippet: TRIGGERS=true

Notes:

- You can only use this parameter if you have specified the SOH group.
- This parameter can be called with the [ENVIRONMENT](#) and [TIMING](#) parameters.
- Several SOH groups may be selected and multiple groups can be downloaded in a single request.
- Refer to [SOH Groups](#) for a listing of the data available for each SOH group.

Millis

Use this parameter to define the start and end time for the digitized time-series or SOH data.

Format: {start|end}Millis=<{start|end} time in milliseconds since epoch>

Select:

- `start` to define the start time for retrieving data in Milliseconds.
- `end` to define the end time for retrieving data in Milliseconds.

Example snippet: `startMillis=<start time in milliseconds since epoch>`

SOH Groups

Environment SOH	Timing SOH	Triggers SOH
Supply voltage	Location	Start time
Total current	GNSS receiver status	Duration
Temperature	GNSS satellites used	Channel
	Timing status	Votes
	Timing phase lock	
	Timing uncertainty	

7.4 State of Health API

Use this API to retrieve the current status of all SOH channels on the specified instrument in JSON format. This API also allows you to share the information with other applications such as external reporting tools.

BASE URI

`/api/v1/instruments/soh`

Parameters

instrumentId

Use this parameter to specify the target instrument.

Format: `instrumentId=[instrumentId]`

Example snippet: `instrumentId=titanSMA__0242`

Notes:

- If you do not specify an instrument, the instrument will report its own SOH.

pretty

Use this parameter to retrieve the data in human-readable format.

Format: `pretty={true|false}`

Select:

- `true` to output the requested data in human-readable format.
- `false` to output the requested data in machine language.

Example snippet: `pretty=true`

7.5 Instrument response API

Use this API to download overall instrument response of the TitanSMA and the attached Nanometrics sensors. The response is based on the current instrument configuration.

BASE URIs

Use the following URI to return a dataless SEED file.

```
/api/v1/responses/channels.dataless
```

Use the following URI to return an IRIS RESP file.

```
/api/v1/responses/channels.resp
```

Use the following URI to return a JSON file.

```
/api/v1/responses/channels.json
```

Parameters

allInOne

Use this parameter to gather the responses for all channels into a single file for downloading.

Format: `allInOne={true|false}`

Select:

- `true` to return a single file containing data for all channels.
- `false` to return a single zip file that contains multiple files. Each file that is included in the zip file contains data for a single channel.

Example snippet: `allInOne=true`

8.0 Reference Information

This section contains information on everything from technical specifications to physical features and dimensions.

8.1 Technical Specifications

The specifications for the TitanSMA are listed in the following sections:

Accelerometer technology	Data recording and retrieval
Accelerometer performance	Timing
Digitizer performance	Physical
Calibration	Power
Events	Interface
Communications	Environmental

8.1.1 Accelerometer Technology

Topology

Triaxial, horizontal-vertical

Feedback

Force balance with capacitive displacement transducer

Centring

Electronic offset zeroing via user interface

8.1.2 Accelerometer Performance

Full-scale Range

Electronically selectable range: $\pm 4\text{ g}$, $\pm 2\text{ g}$, $\pm 1\text{ g}$, $\pm 0.5\text{ g}$, $\pm 0.25\text{ g}$, $\pm 0.125\text{ g}$ (nominal)

Bandwidth

DC to 430 Hz (-3 dB point)

Dynamic Range (Integrated RMS)

169 dB at 1 Hz over 1 Hz bandwidth

Offset

Electronically zeroed to within ± 0.005 g

Non-linearity

< 0.015% total non-linearity

Hysteresis

<0.005% of full-scale

Cross-axis Sensitivity

Less than 0.5% total

Offset Temperature Coefficient

Horizontal sensor: $60 \mu\text{g}/^\circ\text{C}$, typical

Vertical sensor: $320 \mu\text{g}/^\circ\text{C}$, typical

8.1.3 Digitizer Performance**Channels**

3 internal X, Y, and Z axes

Type

True 24-bit ADC per channel, simultaneous sampling

Sensitivity

2, 4, 8, 16, 32, and 64 digitizer counts per μg , $\pm 1\%$

Sample Rates

1, 2, 5, 10, 20, 40, 50, 80, 100, 125, 200, 250, 500, 1000, 2000, and 5000 sps

Dual Sample Rates

A second sample rate can be selected from the sample rates above

Anti-alias Decimation Filters

Filter types: Linear phase (contact Nanometrics for other options)

- Linear phase (also known as non-causal or acausal). Selectable for all samples rates.
- Minimum phase (also known as causal). Selectable for all samples rates except 80 and 2000 sps.

Attenuation: 140 dB (linear phase) or 120 dB (minimum phase) at output Nyquist, 0 dB at 80% Nyquist frequency

Anti-aliasing filter latency (in seconds)

Sample rate	Linear phase	Minimum phase
1	62.088	10.088
2	30.962	4.962
5	12.088	1.688
10	6.1722	0.9722
20	3.1042	0.5042
40	1.579	0.2479
50	1.1947	0.1547
80	0.6382	n/a
100	0.6042	0.0842

Sample rate	Linear phase	Minimum phase
125	0.5007	0.0847
200	0.3039	0.0439
250	0.2431	0.0351
500	0.1237	0.0197
1000	0.061	0.009
2000	0.0207	n/a
5000	0.0085	0.0013

Digital Filters

Low-pass and high-pass high-quality digital Butterworth filters, independently user configurable from first to fifth order with corner frequencies from 0.1 mHz to 50% of sample rate. Sum of low- and high-pass filter orders acting on any given channel is 5 or less.

Different filters may be independently configured for primary and secondary sample rates. This filter capability can be used for a wide variety of applications including DC removal.

Dynamic Range

142dB @ 100 sps, 135 dB @ 500 sps (full-scale peak to RMA shorted-input noise)

8.1.4 Calibration

Digital Calibration

Playback audio files can be created using standard .wav file editors

- Step, Pseudo random binary (PRB), and 1 Hz sine audio files pre-installed
- User can install custom waveforms
- ± 2 g full-scale

8.1.5 Events

Type

Bandpassed STA/LTA or threshold

Trigger Selection

Independent threshold or STA/LTA ratio for each channel

STA/LTA Trigger

Configurable STA, LTA, LTA latching, trigger and de-trigger thresholds

Trigger Votes

User set votes assigned by channel, transmitted via IP multicast

Threshold Trigger

User configurable thresholds

Data Products

Peak Ground Motion (PGA, PGD, PGV) statistics available on instrument

8.1.6 Communications

Interfaces

10/100 Base-T Ethernet. (To reduce power consumption, the [Ethernet speed](#) can be set to 10 Base-T.)

IP Addressing

Static IP or DHCP

Protocols

UDP/IP (unicast/multicast), or HTTP-based (inbound or outbound) streaming

8.1.7 Data Recording and Retrieval

Internal Storage

8 GB flash memory, (expandable up to 64 GB on models TSMA3– or later)

Removable Media

SD media card (formatted as FAT) up to 64 GB

Data Retrieval

Direct download via Ethernet

Media Exchange

SD card field-swappable during continuous recording with no loss of data if swapped within one hour

8.1.8 Timing

Timing System

Selectable time source:

- Internal DCXO clock disciplined to GNSS
- External PTP v1 (IEEE 1588-2002) high-precision timing source option
- External NTP timing source option
- Free-running timing source option that allows the instrument to run at the accuracy of the internal oscillator

Selectable time server. Can act as a time server, providing network timing to other devices:

- PTP v1 (IEEE 1588-2002) high-precision timing server option
- NTP timing server option

Timing Accuracy

* Time source	** Accuracy (typical)	*** Jamset threshold	Maximum slewing correction time (Approximate)
GNSS always-on	< 5 μ sec	1000 μ sec	3 minutes
GNSS duty-cycled	< 100 μ sec	1000 μ sec	3 minutes
PTP (LAN)	< 50 μ sec	2000 μ sec	6 minutes
NTP (LAN)	< 100 μ sec	20 msec	60 minutes
NTP (Campus)	< 300 μ sec	20 msec	60 minutes
NTP (Internet)	< 2 msec	20 msec	60 minutes



* Time source **NTP (Campus)** describes multiple private subnets connected together.

** Accuracy for GNSS, assumes an antenna with a clear view of the sky and good signal. For PTP or NTP, achieving the highest accuracy requires that users employ industry best practices when configuring their networks.

*** A jamset is when the system determines that its internal clock is sufficiently different from the time source it is tracking, that it abruptly resets its time to match the source. This will cause a brief gap in recording as the anti-aliasing filters are flushed, and will also create apparent overlaps or gaps in the data depending on whether the new time is earlier or later than the old system time. The behaviour is as follows:

- below threshold, the system time slews to gradually adjust to source time, so that no gaps or overlaps are created
- above threshold, an abrupt time adjustment ("jamset") is applied

8.1.9 Physical

Size

Length: 18 cm

Width: 11.8 cm

Height: 10.2 cm (without levelling screws)

Weight

2.6 kg

Housing

Aluminum

Surface resistant to corrosion, scratches, and chips

Mounting

Single bolt keyhole mount

Levelling

- Integrated bubble level
- Adjustable locking levelling screws (4)
- Optional fixed-foot for three-foot freestanding installations (included with installation kit)

8.1.10 Power

Supply Voltage

9-36 V DC isolated input



Note that the instrument can operate down to 9 V once started.

Consumption

1.8 W quiescent, no Ethernet, duty-cycled GNSS (nominal)



- If Ethernet is used and speed is set to 10Base-T, add 200 mW to the above numbers.
- If Ethernet is used and speed is set to 100Base-T, add 300 mW to the above numbers.
- If GNSS power mode is set to Always on, add 350 mW to the above numbers.
- Power usage increases at colder temperatures, up to 7% higher at -45°C.



Model TSMA3— has approximately 100 mW lower power consumption than the approximate values listed in this section.

Protection

Reverse-voltage and over- and under-voltage protected

Self-resetting over-current protection

Isolation

Supply power is isolated from signal ground

Grounding

Predrilled holes (4) for M4 X 5 grounding lug screw

Low/High Voltage Disconnect

Software configurable

8.1.11 Connectors

(External)

Power:

- 3-pin, shell size 8
- MIL-C-26482G Series 1
- Recommended mate: MS3116J8-3S

Ethernet

- 4-socket, shell size 8
- Insert position W
- MIL-C-26482G Series 1
- 10/100 Base-T
- Recommended mate: MS3116J8-4PW

GNSS

- **TNC**¹ female
- Recommended mate: TNC male

USB

- USB 2.0 type A, female
- Recommended mate: USB 2.0 type A, male

Connectors (Internal)

SD card slot

Status LEDs

Power, Ethernet, Timing, Media, Event notification, overall Status

Graphical User Interface (GUI)

Provided via onboard Web server. Use GUI for :

- State-of-health and waveform monitoring
- Viewing and downloading events
- Calibration, configuration, and maintenance

8.1.12 Environmental

Operating Temperature

-20°C to +60°C (Ultra-low temperature option available. Please contact Nanometrics.)

¹Threaded Neill-Concelman

Storage Temperature

-40° C to +70° C

Humidity

0 to 100%

Weather Resistance

Rated to IP-67

8.2 Performance

[Sensitivities](#)

[Frequency Response](#)

[Self-noise](#)

8.2.1 Sensitivities

The sensitivities of the internal accelerometer are as follows, in digital recorder counts per μg , $\pm 1\%$:

Clip level	Sensitivity
(g)	(counts/ μg)
4	2
2	4
1	8
0.5	16
0.25	32
0.125	64



If ground motion exceeds the sensor clip level, the signal processing algorithms that limit the signal bandwidth to match the sample rate will sometimes produce values with magnitudes greater than the clip level. This is intentional and represents a better estimate of actual ground motion amplitude than the clipped signal would.

8.2.2 Frequency Response

The accelerometer sensitivity, poles, and zeros define the transfer function according to the following equation:

$$F(s) = S \cdot k \cdot \frac{\prod_n (s - z_n)}{\prod_n (s - p_n)}$$

Where the normalization factor is defined by the following equation and is given for informational purposes only.

$$k = \left| \frac{\prod_n (i2^\pi f_0 - p_n)}{\prod_n (i2^\pi f_0 - z_n)} \right|$$

Titan accelerometer poles and zeros

Symbol	Parameter	Nominal Values	Units
z_n	Zeros	-515	rad/s
p_n	Poles	-977 ±328i -1486 ±2512i -5736 ±4946i	rad/s
k	Normalization factor	1.0077×10^{18}	(rad/s) ⁵
f_0	Normalization frequency	1	Hz

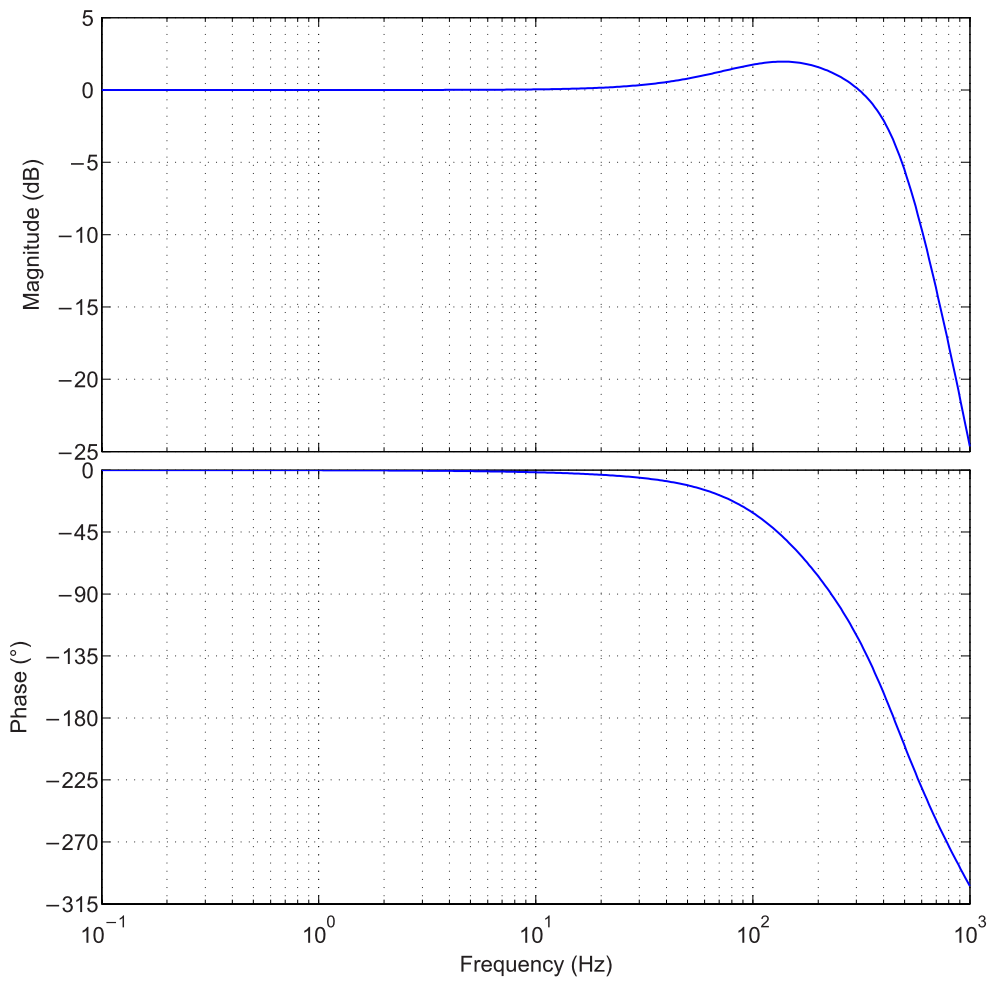

8.2.3 Self-Noise

The plot shows the typical self-noise for the TitanSMA. Two curves are included for reference: Peterson's¹ **NLNM**¹ and **NHNM**². The noise floor shown is the typical level of instrument self-noise assuming proper installation.

¹New Low-noise Model

²New High-noise Model

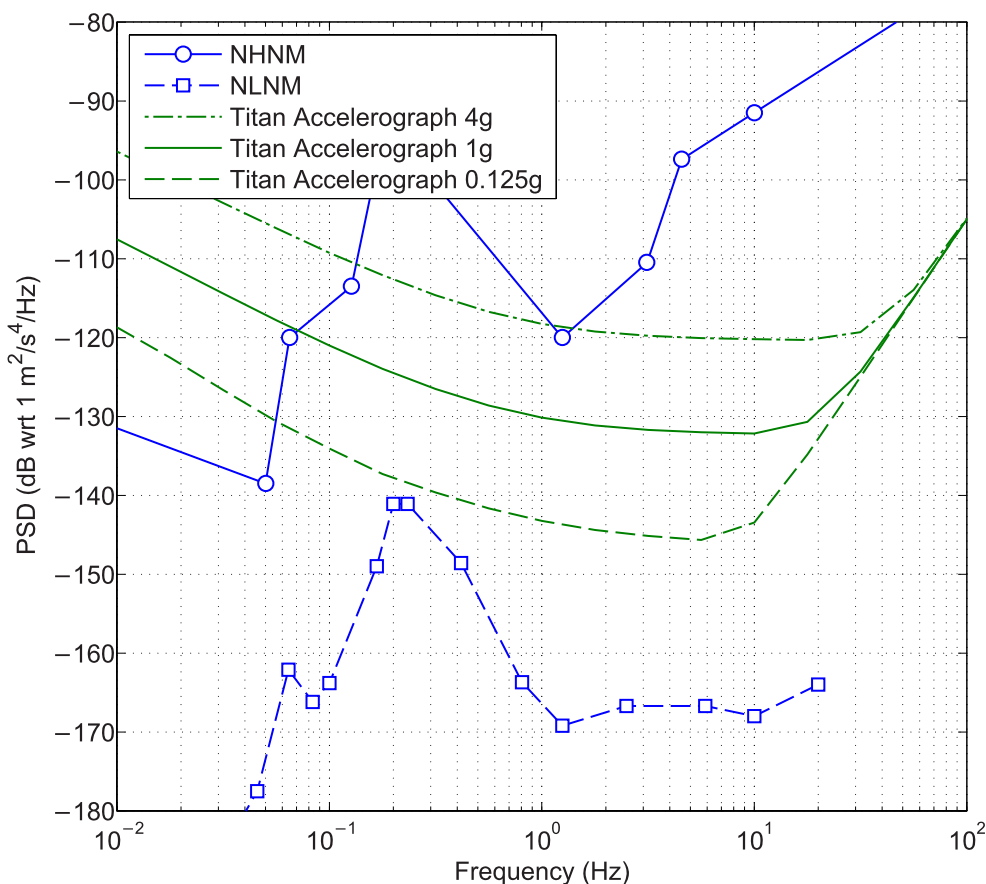

¹Jon Peterson, *Observations and Modeling of Seismic Background Noise*, Open-File Report 93-322 (Albuquerque, New Mexico, U.S. Department of Interior Geological Survey, 1993).

8.3 SOH channels in Steim compressed formats

The TitanSMA stores selected SOH channels in Steim compressed formats. This data can be [retrieved from the internal storage](#), streamed via SEEDLink or downloaded in MiniSEED format via the [Maintenance](#) page. Note that the External SOH and Sensor SOH do not apply to the TitanSMA.

Code	Description	Units	Notes
EX1	External SOH channels	microvolts	
EX2	1 to 3		
EX3			

Code	Description	Units	Notes
LCE	Absolute clock phase error	microseconds	The difference between the digitizer clock and the GPS receiver. When GNSS value is off or unlocked, as indicated by GST, the LCE value will be 0.
LCQ	Clock quality		<p>A heuristic time quality value that can be defined as follows:</p> <ul style="list-style-type: none"> • 100% means that the system locked to GNSS with time error < 5 μs • 90% signifies an estimated time error of < 100 μs (GNSS duty cycling, or coarse locked) • 70% signifies an estimated time error of < 200 μs (GNSS coarse locked or system free running) • <70% decrements from 70% by 1% for each hour free running • 0% means that the system has never locked or been free running for more than 70 hours
VCO	VCO control voltage (for timing oscillator)	raw DAC counts	
VEC	Digitizer system current	milliamps	
VM1 VM2 VM3	Sensor SOH channels 1 to 3	microvolts	<p>This value represents mass position.</p> <ul style="list-style-type: none"> • VM1 = W axis • VM2 = V axis • VM3 = U axis
VPB	Digitizer buffer percent used		This value is typically 100% once the buffer is full.

Code	Description	Units	Notes
GNS	GNSS number of satellites used		The number of satellites used by the timing solution. If the GNSS receiver status is off as indicated by GST, the last known value is preserved.
GLA	GNSS latitude	microdegrees	
GLO	GNSS longitude	microdegrees	
GEL	GNSS elevation	micrometres	
GST	GNSS status		0=off, 1=unlocked, 2=locked
GPL	GNSS PLL status		0=no lock, 1=coarse lock, 2=fine lock, 3=free running
VDT	Digitizer system temperature	millidegrees Celsius	
VEI	Input system voltage	millivolts	
GAN	GNSS antenna status		0=ok, 1=no antenna, 2=antenna short

8.4 Connectors and Pinouts

This section does not include pinouts for industry standard connectors. See the [Technical Specifications](#) for the full list of connectors.

- [Ethernet](#)
- [Power connector](#)

8.4.1 Ethernet Connector Receptacle and Pinout

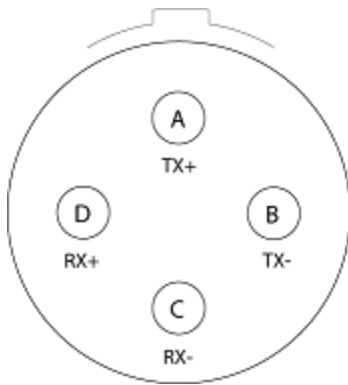

Connector type:

- 4-socket, shell size 8
- Insert position W
- MIL-C-26482G Series 1
- 10/100 Base-T

Recommended mating connector:

- MS3116J8-4PW

Pin	Name	Function
A	TX+	Ethernet MTL-3 Transmit +
B	TX-	Ethernet MTL-3 Transmit -
C	RX-	Ethernet MTL-3 Receive -
D	RX+	Ethernet MTL-3 Receive +

8.4.2 Power Connector Receptacle and Pinout

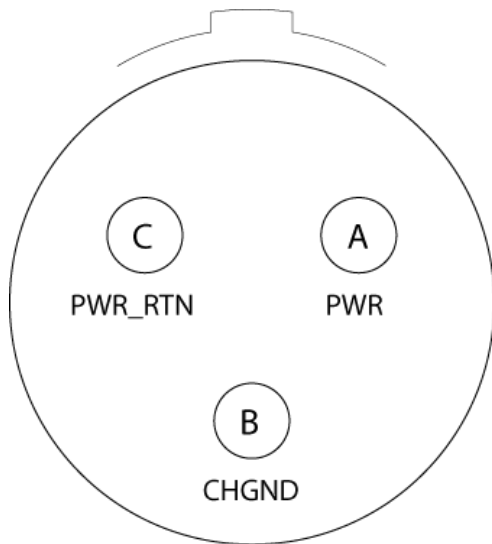

Connector type:

- 3-pin, shell size 8
- MIL-C-26482G Series 1

Recommended mating connector:

- Souriau 851-06JC8-3AS

Pin	Name	Function
A	PWR	Raw (battery) power in (9 V to 36 V DC)
B	CHGND	Internal connection to chassis ground
C	PWR_RTN	Raw power return

8.5 Physical Features and Dimensions

Refer to the following figures to view the features and dimensions. All dimensions in the figures are in millimetres unless otherwise stated.

- [Top View](#)
- [Bottom View](#)
- [Side View](#)
- [View of External Connectors](#)
- [View of Open Media Bay Door](#)

8.5.1 Top View of the TitanSMA



Dimensions are in millimetres unless otherwise stated.

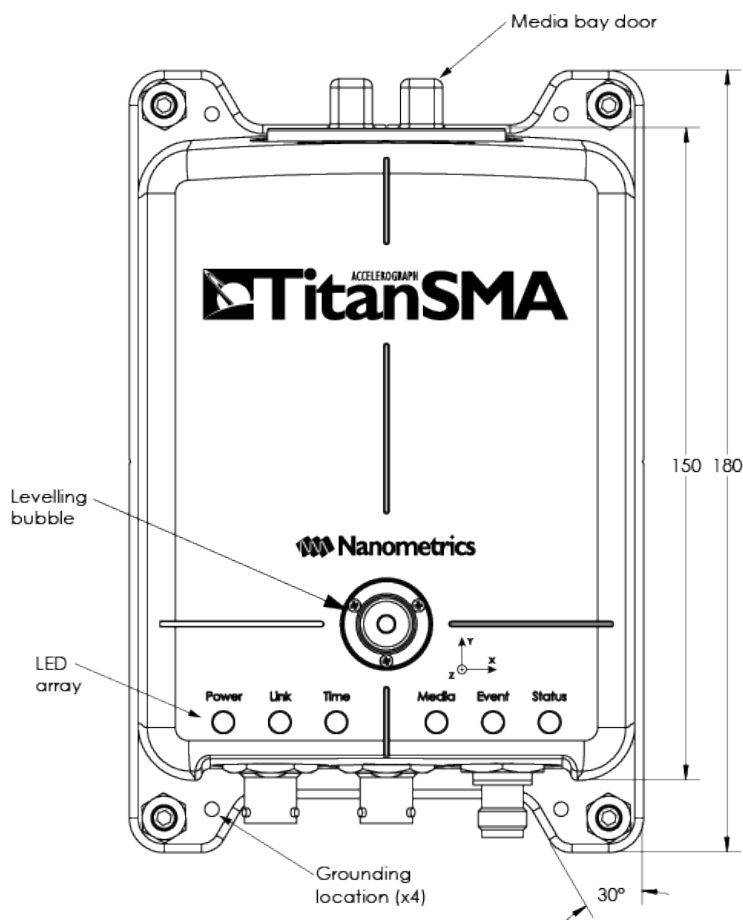

8.5.2 Bottom View



Dimensions are in millimetres unless otherwise stated.

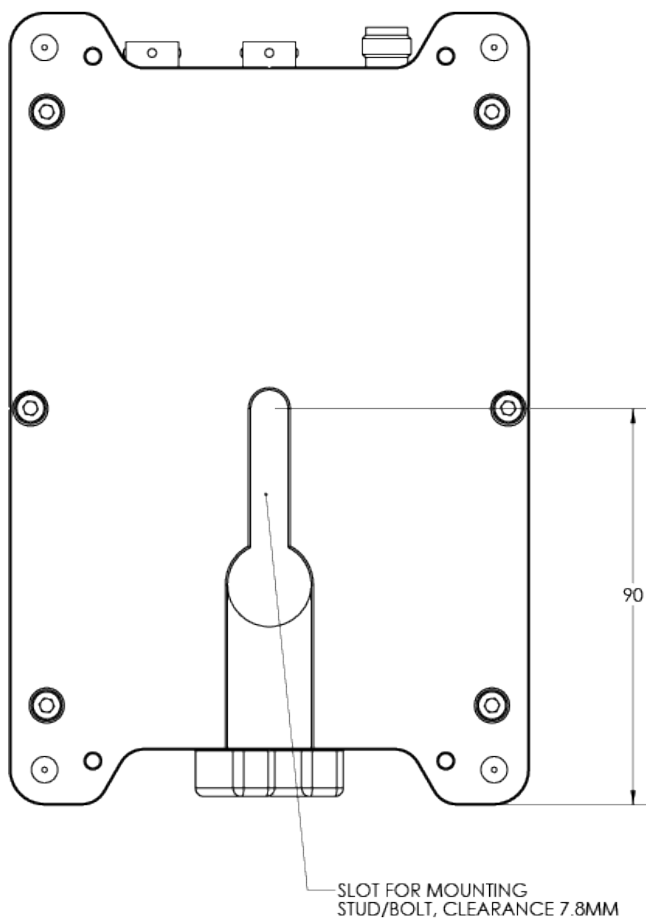

8.5.3 Side View of the TitanSMA

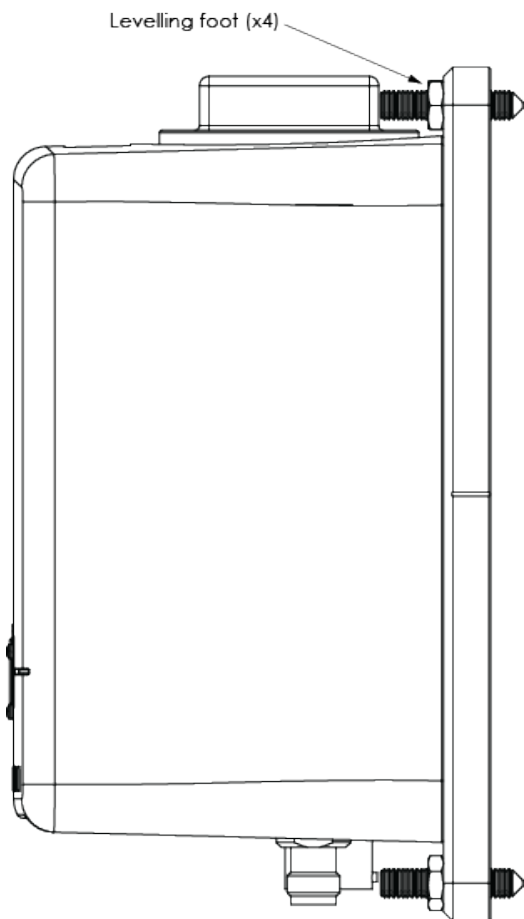

8.5.4 View of the External Connectors



Dimensions are in millimetres unless otherwise stated.

Connectors:
Power
Ethernet
GPS

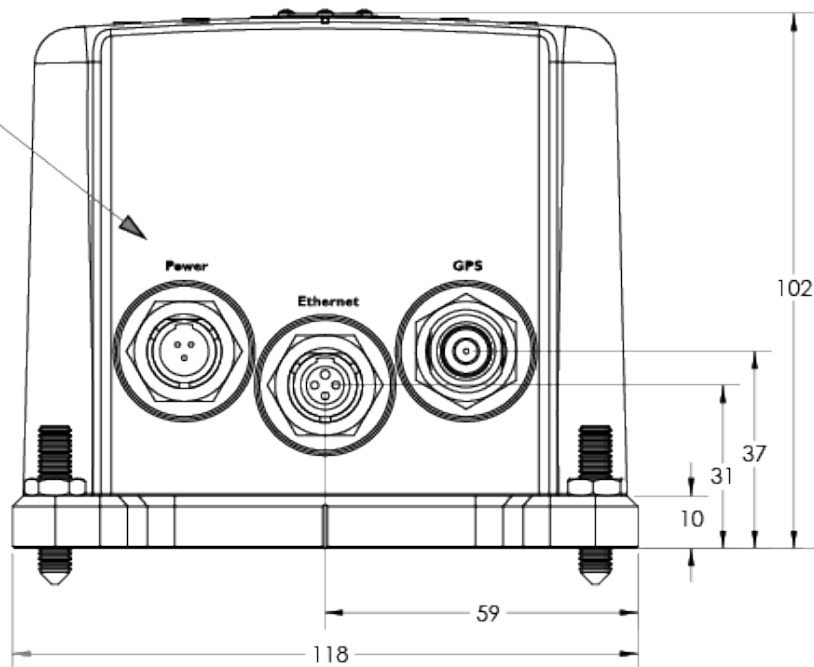

8.5.5 View of Open Media Bay

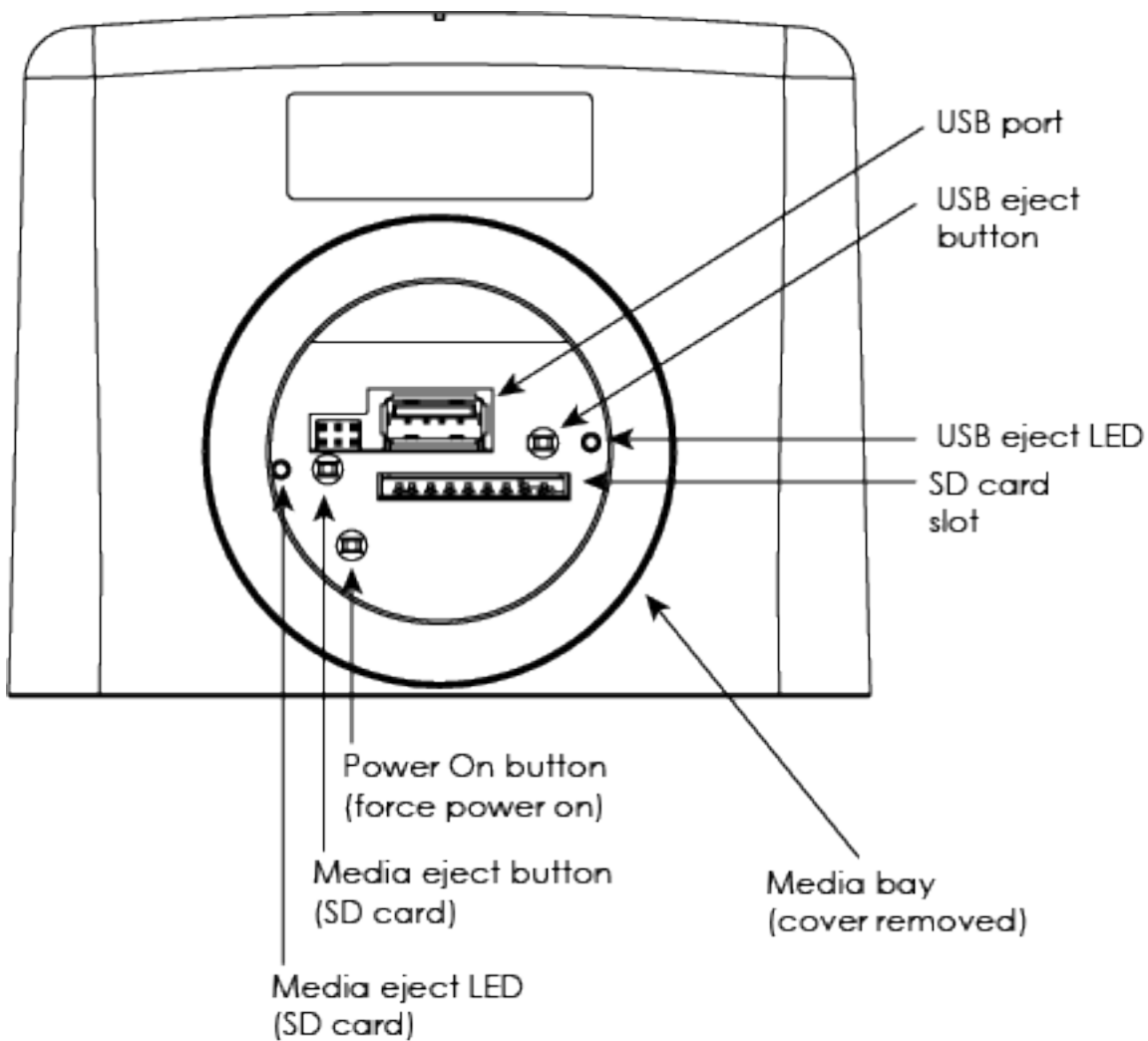

8.6 Open Source Attributions

Discrete portions of the Nanometrics software product may include open source software code. Please see the attribution notices below.

8.6.1 Apache License

Copyright © 2015 The Apache Software Foundation, Licensed under the Apache License, Version 2.0 (the "License"); you may not use this file except in compliance with the License.

You may obtain a copy of the License at <http://www.apache.org/licenses/LICENSE-2.0>

Unless required by applicable law or agreed to in writing, software distributed under the License is distributed on an "AS IS" BASIS, WITHOUT WARRANTIES OR CONDITIONS OF ANY KIND, either express or implied. See the License for the specific language governing permissions and limitations under the License.

8.6.2 Bouncy Castle

Copyright (c) 2000 - 2015 The Legion of the Bouncy Castle Inc. (<http://www.bouncycastle.org>)

Permission is hereby granted, free of charge, to any person obtaining a copy of this software and associated documentation files (the "Software"), to deal in the Software without restriction, including without limitation the rights to use, copy, modify, merge, publish, distribute, sublicense, and/or sell copies of the Software, and to permit persons to whom the Software is furnished to do so, subject to the following conditions:

The above copyright notice and this permission notice shall be included in all copies or substantial portions of the Software.

THE SOFTWARE IS PROVIDED "AS IS", WITHOUT WARRANTY OF ANY KIND, EXPRESS OR IMPLIED, INCLUDING BUT NOT LIMITED TO THE WARRANTIES OF MERCHANTABILITY, FITNESS FOR A PARTICULAR PURPOSE AND NONINFRINGEMENT. IN NO EVENT SHALL THE AUTHORS OR COPYRIGHT HOLDERS BE LIABLE FOR ANY CLAIM, DAMAGES OR OTHER LIABILITY, WHETHER IN AN ACTION OF CONTRACT, TORT OR OTHERWISE, ARISING FROM, OUT OF OR IN CONNECTION WITH THE SOFTWARE OR THE USE OR OTHER DEALINGS IN THE SOFTWARE.

8.6.3 BSD-2

Copyright (c) 1998, Regents of the University of California

All rights reserved. Redistribution and use in source and binary forms, with or without modification, are permitted provided that the following conditions are met:

1. Redistributions of source code must retain the above copyright notice, this list of conditions and the following disclaimer.
2. Redistributions in binary form must reproduce the above copyright notice, this list of conditions and the following disclaimer in the documentation and/or other materials provided with the distribution.

THIS SOFTWARE IS PROVIDED BY THE COPYRIGHT HOLDERS AND CONTRIBUTORS "AS IS" AND ANY EXPRESS OR IMPLIED WARRANTIES, INCLUDING, BUT NOT LIMITED TO, THE IMPLIED WARRANTIES OF MERCHANTABILITY AND FITNESS FOR A PARTICULAR PURPOSE ARE DISCLAIMED. IN NO EVENT SHALL THE COPYRIGHT HOLDER OR CONTRIBUTORS BE LIABLE FOR ANY DIRECT, INDIRECT, INCIDENTAL, SPECIAL, EXEMPLARY, OR CONSEQUENTIAL DAMAGES (INCLUDING, BUT NOT LIMITED TO, PROCUREMENT OF SUBSTITUTE GOODS OR SERVICES; LOSS OF

USE, DATA, OR PROFITS; OR BUSINESS INTERRUPTION) HOWEVER CAUSED AND ON ANY THEORY OF LIABILITY, WHETHER IN CONTRACT, STRICT LIABILITY, OR TORT (INCLUDING NEGLIGENCE OR OTHERWISE) ARISING IN ANY WAY OUT OF THE USE OF THIS SOFTWARE, EVEN IF ADVISED OF THE POSSIBILITY OF SUCH DAMAGE.

8.6.4 COMMON DEVELOPMENT AND DISTRIBUTION LICENSE Version 1.0 (CDDL-1.0)

1. Definitions.

1.1. Contributor means each individual or entity that creates or contributes to the creation of Modifications.

1.2. Contributor Version means the combination of the Original Software, prior Modifications used by a Contributor (if any), and the Modifications made by that particular Contributor.

1.3. Covered Software means (a) the Original Software, or (b) Modifications, or (c) the combination of files containing Original Software with files containing Modifications, in each case including portions thereof.

1.4. Executable means the Covered Software in any form other than Source Code.

1.5. Initial Developer means the individual or entity that first makes Original Software available under this License.

1.6. Larger Work means a work which combines Covered Software or portions thereof with code not governed by the terms of this License.

1.7. License means this document.

1.8. Licensable means having the right to grant, to the maximum extent possible, whether at the time of the initial grant or subsequently acquired, any and all of the rights conveyed herein.

1.9. Modifications means the Source Code and Executable form of any of the following:

A. Any file that results from an addition to, deletion from or modification of the contents of a file containing Original Software or previous Modifications;

B. Any new file that contains any part of the Original Software or previous Modification; or

C. Any new file that is contributed or otherwise made available under the terms of this License.

1.10. Original Software means the Source Code and Executable form of computer software code that is originally released under this License.

1.11. Patent Claims means any patent claim(s), now owned or hereafter acquired, including without limitation, method, process, and apparatus claims, in any patent Licensable by grantor.

1.12. Source Code means (a) the common form of computer software code in which modifications are made and (b) associated documentation included in or with such code.

1.13. You (or Your) means an individual or a legal entity exercising rights under, and complying with all of the terms of, this License. For legal entities, You includes any entity which controls, is controlled by, or is under common control with You. For purposes of this definition, control means (a) the power, direct or indirect, to cause the direction or management of such entity, whether by contract or otherwise, or (b) ownership of more than fifty percent (50%) of the outstanding shares or beneficial ownership of such entity.

2. License Grants.

2.1. The Initial Developer Grant.

Conditioned upon Your compliance with Section 3.1 below and subject to third party intellectual property claims, the Initial Developer hereby grants You a world-wide, royalty-free, non-exclusive license:

(a) under intellectual property rights (other than patent or trademark) Licensable by Initial Developer, to use, reproduce, modify, display, perform, sublicense and distribute the Original Software (or portions thereof), with or without Modifications, and/or as part of a Larger Work; and

(b) under Patent Claims infringed by the making, using or selling of Original Software, to make, have made, use, practice, sell, and offer for sale, and/or otherwise dispose of the Original Software (or portions thereof).

(c) The licenses granted in Sections 2.1(a) and (b) are effective on the date Initial Developer first distributes or otherwise makes the Original Software available to a third party under the terms of this License.

(d) Notwithstanding Section 2.1(b) above, no patent license is granted: (1) for code that You delete from the Original Software, or (2) for infringements caused by: (i) the modification of the Original Software, or (ii) the combination of the Original Software with other software or devices.

2.2. Contributor Grant.

Conditioned upon Your compliance with Section 3.1 below and subject to third party intellectual property claims, each Contributor hereby grants You a world-wide, royalty-free, non-exclusive license:

(a) under intellectual property rights (other than patent or trademark) Licensable by Contributor to use, reproduce, modify, display, perform, sublicense and distribute the Modifications created by such Contributor (or portions thereof), either on an unmodified basis, with other Modifications, as Covered Software and/or as part of a Larger Work; and

(b) under Patent Claims infringed by the making, using, or selling of Modifications made by that Contributor either alone and/or in combination with its Contributor Version (or portions of such combination), to make, use, sell, offer for sale, have made, and/or otherwise dispose of: (1) Modifications made by that Contributor (or portions thereof); and (2) the combination of Modifications made by that Contributor with its Contributor Version (or portions of such combination).

(c) The licenses granted in Sections 2.2(a) and 2.2(b) are effective on the date Contributor first distributes or otherwise makes the Modifications available to a third party.

(d) Notwithstanding Section 2.2(b) above, no patent license is granted: (1) for any code that Contributor has deleted from the Contributor Version; (2) for infringements caused by: (i) third party modifications of Contributor Version, or (ii) the combination of Modifications made by that Contributor with other software (except as part of the Contributor Version) or other devices; or (3) under Patent Claims infringed by Covered Software in the absence of Modifications made by that Contributor.

3. Distribution Obligations.

3.1. Availability of Source Code.

Any Covered Software that You distribute or otherwise make available in Executable form must also be made available in Source Code form and that Source Code form must be distributed only under the terms of this License. You must include a copy of this License with every copy of the Source Code form of the Covered Software You distribute or otherwise make available. You must inform recipients of any such Covered Software in Executable form as to how they can obtain such Covered Software in Source Code form in a reasonable manner on or through a medium customarily used for software exchange.

3.2. Modifications.

The Modifications that You create or to which You contribute are governed by the terms of this License. You represent that You believe Your Modifications are Your original creation(s) and/or You have sufficient rights to grant the rights conveyed by this License.

3.3. Required Notices.

You must include a notice in each of Your Modifications that identifies You as the Contributor of the Modification. You may not remove or alter any copyright, patent or trademark notices contained within the

Covered Software, or any notices of licensing or any descriptive text giving attribution to any Contributor or the Initial Developer.

3.4. Application of Additional Terms.

You may not offer or impose any terms on any Covered Software in Source Code form that alters or restricts the applicable version of this License or the recipients rights hereunder. You may choose to offer, and to charge a fee for, warranty, support, indemnity or liability obligations to one or more recipients of Covered Software. However, you may do so only on Your own behalf, and not on behalf of the Initial Developer or any Contributor. You must make it absolutely clear that any such warranty, support, indemnity or liability obligation is offered by You alone, and You hereby agree to indemnify the Initial Developer and every Contributor for any liability incurred by the Initial Developer or such Contributor as a result of warranty, support, indemnity or liability terms You offer.

3.5. Distribution of Executable Versions.

You may distribute the Executable form of the Covered Software under the terms of this License or under the terms of a license of Your choice, which may contain terms different from this License, provided that You are in compliance with the terms of this License and that the license for the Executable form does not attempt to limit or alter the recipients rights in the Source Code form from the rights set forth in this License. If You distribute the Covered Software in Executable form under a different license, You must make it absolutely clear that any terms which differ from this License are offered by You alone, not by the Initial Developer or Contributor. You hereby agree to indemnify the Initial Developer and every Contributor for any liability incurred by the Initial Developer or such Contributor as a result of any such terms You offer.

3.6. Larger Works.

You may create a Larger Work by combining Covered Software with other code not governed by the terms of this License and distribute the Larger Work as a single product. In such a case, You must make sure the requirements of this License are fulfilled for the Covered Software.

4. Versions of the License.

4.1. New Versions.

Sun Microsystems, Inc. is the initial license steward and may publish revised and/or new versions of this License from time to time. Each version will be given a distinguishing version number. Except as provided in Section 4.3, no one other than the license steward has the right to modify this License.

4.2. Effect of New Versions.

You may always continue to use, distribute or otherwise make the Covered Software available under the terms of the version of the License under which You originally received the Covered Software. If the Initial Developer includes a notice in the Original Software prohibiting it from being distributed or otherwise made available under any subsequent version of the License, You must distribute and make the Covered Software available under the terms of the version of the License under which You originally received the Covered Software. Otherwise, You may also choose to use, distribute or otherwise make the Covered Software available under the terms of any subsequent version of the License published by the license steward.

4.3. Modified Versions.

When You are an Initial Developer and You want to create a new license for Your Original Software, You may create and use a modified version of this License if You: (a) rename the license and remove any references to the name of the license steward (except to note that the license differs from this License); and (b) otherwise make it clear that the license contains terms which differ from this License.

5. DISCLAIMER OF WARRANTY.

COVERED SOFTWARE IS PROVIDED UNDER THIS LICENSE ON AN AS IS BASIS, WITHOUT WARRANTY OF ANY KIND, EITHER EXPRESSED OR IMPLIED, INCLUDING, WITHOUT LIMITATION, WARRANTIES THAT THE COVERED

SOFTWARE IS FREE OF DEFECTS, MERCHANTABLE, FIT FOR A PARTICULAR PURPOSE OR NON-INFRINGEMENT. THE ENTIRE RISK AS TO THE QUALITY AND PERFORMANCE OF THE COVERED SOFTWARE IS WITH YOU. SHOULD ANY COVERED SOFTWARE PROVE DEFECTIVE IN ANY RESPECT, YOU (NOT THE INITIAL DEVELOPER OR ANY OTHER CONTRIBUTOR) ASSUME THE COST OF ANY NECESSARY SERVICING, REPAIR OR CORRECTION. THIS DISCLAIMER OF WARRANTY CONSTITUTES AN ESSENTIAL PART OF THIS LICENSE. NO USE OF ANY COVERED SOFTWARE IS AUTHORIZED HEREUNDER EXCEPT UNDER THIS DISCLAIMER.

6. TERMINATION.

6.1. This License and the rights granted hereunder will terminate automatically if You fail to comply with terms herein and fail to cure such breach within 30 days of becoming aware of the breach. Provisions which, by their nature, must remain in effect beyond the termination of this License shall survive.

6.2. If You assert a patent infringement claim (excluding declaratory judgment actions) against Initial Developer or a Contributor (the Initial Developer or Contributor against whom You assert such claim is referred to as Participant) alleging that the Participant Software (meaning the Contributor Version where the Participant is a Contributor or the Original Software where the Participant is the Initial Developer) directly or indirectly infringes any patent, then any and all rights granted directly or indirectly to You by such Participant, the Initial Developer (if the Initial Developer is not the Participant) and all Contributors under Sections 2.1 and/or 2.2 of this License shall, upon 60 days notice from Participant terminate prospectively and automatically at the expiration of such 60 day notice period, unless if within such 60 day period You withdraw Your claim with respect to the Participant Software against such Participant either unilaterally or pursuant to a written agreement with Participant.

6.3. In the event of termination under Sections 6.1 or 6.2 above, all end user licenses that have been validly granted by You or any distributor hereunder prior to termination (excluding licenses granted to You by any distributor) shall survive termination.

7. LIMITATION OF LIABILITY.

UNDER NO CIRCUMSTANCES AND UNDER NO LEGAL THEORY, WHETHER TORT (INCLUDING NEGLIGENCE), CONTRACT, OR OTHERWISE, SHALL YOU, THE INITIAL DEVELOPER, ANY OTHER CONTRIBUTOR, OR ANY DISTRIBUTOR OF COVERED SOFTWARE, OR ANY SUPPLIER OF ANY OF SUCH PARTIES, BE LIABLE TO ANY PERSON FOR ANY INDIRECT, SPECIAL, INCIDENTAL, OR CONSEQUENTIAL DAMAGES OF ANY CHARACTER INCLUDING, WITHOUT LIMITATION, DAMAGES FOR LOST PROFITS, LOSS OF GOODWILL, WORK STOPPAGE, COMPUTER FAILURE OR MALFUNCTION, OR ANY AND ALL OTHER COMMERCIAL DAMAGES OR LOSSES, EVEN IF SUCH PARTY SHALL HAVE BEEN INFORMED OF THE POSSIBILITY OF SUCH DAMAGES. THIS LIMITATION OF LIABILITY SHALL NOT APPLY TO LIABILITY FOR DEATH OR PERSONAL INJURY RESULTING FROM SUCH PARTYS NEGLIGENCE TO THE EXTENT APPLICABLE LAW PROHIBITS SUCH LIMITATION. SOME JURISDICTIONS DO NOT ALLOW THE EXCLUSION OR LIMITATION OF INCIDENTAL OR CONSEQUENTIAL DAMAGES, SO THIS EXCLUSION AND LIMITATION MAY NOT APPLY TO YOU.

8. U.S. GOVERNMENT END USERS.

The Covered Software is a commercial item, as that term is defined in 48 C.F.R. 2.101 (Oct. 1995), consisting of commercial computer software (as that term is defined at 48 C.F.R. 252.227-7014(a)(1)) and commercial computer software documentation as such terms are used in 48 C.F.R. 12.212 (Sept. 1995). Consistent with 48 C.F.R. 12.212 and 48 C.F.R. 227.7202-1 through 227.7202-4 (June 1995), all U.S. Government End Users acquire Covered Software with only those rights set forth herein. This U.S. Government Rights clause is in lieu of, and supersedes, any other FAR, DFAR, or other clause or provision that addresses Government rights in computer software under this License.

9. MISCELLANEOUS.

This License represents the complete agreement concerning subject matter hereof. If any provision of this License is held to be unenforceable, such provision shall be reformed only to the extent necessary to make

it enforceable. This License shall be governed by the law of the jurisdiction specified in a notice contained within the Original Software (except to the extent applicable law, if any, provides otherwise), excluding such jurisdictions conflict-of-law provisions. Any litigation relating to this License shall be subject to the jurisdiction of the courts located in the jurisdiction and venue specified in a notice contained within the Original Software, with the losing party responsible for costs, including, without limitation, court costs and reasonable attorneys fees and expenses. The application of the United Nations Convention on Contracts for the International Sale of Goods is expressly excluded. Any law or regulation which provides that the language of a contract shall be construed against the drafter shall not apply to this License. You agree that You alone are responsible for compliance with the United States export administration regulations (and the export control laws and regulation of any other countries) when You use, distribute or otherwise make available any Covered Software.

10. RESPONSIBILITY FOR CLAIMS.

As between Initial Developer and the Contributors, each party is responsible for claims and damages arising, directly or indirectly, out of its utilization of rights under this License and You agree to work with Initial Developer and Contributors to distribute such responsibility on an equitable basis. Nothing herein is intended or shall be deemed to constitute any admission of liability.

8.6.5 Eclipse Public License -v 1.0

THE ACCOMPANYING PROGRAM IS PROVIDED UNDER THE TERMS OF THIS ECLIPSE PUBLIC LICENSE ("AGREEMENT"). ANY USE, REPRODUCTION OR DISTRIBUTION OF THE PROGRAM CONSTITUTES RECIPIENT'S ACCEPTANCE OF THIS AGREEMENT.

1. DEFINITIONS

"Contribution" means:

- a) in the case of the initial Contributor, the initial code and documentation distributed under this Agreement, and
- b) in the case of each subsequent Contributor:
 - i) changes to the Program, and
 - ii) additions to the Program;

where such changes and/or additions to the Program originate from and are distributed by that particular Contributor. A Contribution 'originates' from a Contributor if it was added to the Program by such Contributor itself or anyone acting on such Contributor's behalf. Contributions do not include additions to the Program which: (i) are separate modules of software distributed in conjunction with the Program under their own license agreement, and (ii) are not derivative works of the Program.

"Contributor" means any person or entity that distributes the Program.

"Licensed Patents " mean patent claims licensable by a Contributor which are necessarily infringed by the use or sale of its Contribution alone or when combined with the Program.

"Program" means the Contributions distributed in accordance with this Agreement.

"Recipient" means anyone who receives the Program under this Agreement, including all Contributors.

2. GRANT OF RIGHTS

- a) Subject to the terms of this Agreement, each Contributor hereby grants Recipient a non-exclusive, worldwide, royalty-free copyright license to reproduce, prepare derivative works of, publicly display, publicly perform, distribute and sublicense the Contribution of such Contributor, if any, and such derivative works, in source code and object code form.

b) Subject to the terms of this Agreement, each Contributor hereby grants Recipient a non-exclusive, worldwide, royalty-free patent license under Licensed Patents to make, use, sell, offer to sell, import and otherwise transfer the Contribution of such Contributor, if any, in source code and object code form. This patent license shall apply to the combination of the Contribution and the Program if, at the time the Contribution is added by the Contributor, such addition of the Contribution causes such combination to be covered by the Licensed Patents. The patent license shall not apply to any other combinations which include the Contribution. No hardware per se is licensed hereunder.

c) Recipient understands that although each Contributor grants the licenses to its Contributions set forth herein, no assurances are provided by any Contributor that the Program does not infringe the patent or other intellectual property rights of any other entity. Each Contributor disclaims any liability to Recipient for claims brought by any other entity based on infringement of intellectual property rights or otherwise. As a condition to exercising the rights and licenses granted hereunder, each Recipient hereby assumes sole responsibility to secure any other intellectual property rights needed, if any. For example, if a third party patent license is required to allow Recipient to distribute the Program, it is Recipient's responsibility to acquire that license before distributing the Program.

d) Each Contributor represents that to its knowledge it has sufficient copyright rights in its Contribution, if any, to grant the copyright license set forth in this Agreement.

3. REQUIREMENTS

A Contributor may choose to distribute the Program in object code form under its own license agreement, provided that:

a) it complies with the terms and conditions of this Agreement; and

b) its license agreement:

i) effectively disclaims on behalf of all Contributors all warranties and conditions, express and implied, including warranties or conditions of title and non-infringement, and implied warranties or conditions of merchantability and fitness for a particular purpose;

ii) effectively excludes on behalf of all Contributors all liability for damages, including direct, indirect, special, incidental and consequential damages, such as lost profits;

iii) states that any provisions which differ from this Agreement are offered by that Contributor alone and not by any other party; and

iv) states that source code for the Program is available from such Contributor, and informs licensees how to obtain it in a reasonable manner on or through a medium customarily used for software exchange.

When the Program is made available in source code form:

a) it must be made available under this Agreement; and

b) a copy of this Agreement must be included with each copy of the Program.

Contributors may not remove or alter any copyright notices contained within the Program.

Each Contributor must identify itself as the originator of its Contribution, if any, in a manner that reasonably allows subsequent Recipients to identify the originator of the Contribution.

4. COMMERCIAL DISTRIBUTION

Commercial distributors of software may accept certain responsibilities with respect to end users, business partners and the like. While this license is intended to facilitate the commercial use of the Program, the Contributor who includes the Program in a commercial product offering should do so in a manner which does not create potential liability for other Contributors. Therefore, if a Contributor includes the Program in a commercial product offering, such Contributor ("Commercial Contributor") hereby agrees to defend and indemnify every other Contributor ("Indemnified Contributor") against any losses, damages and costs (collectively "Losses") arising from claims, lawsuits and other legal actions brought by a third party against

the Indemnified Contributor to the extent caused by the acts or omissions of such Commercial Contributor in connection with its distribution of the Program in a commercial product offering. The obligations in this section do not apply to any claims or Losses relating to any actual or alleged intellectual property infringement. In order to qualify, an Indemnified Contributor must: a) promptly notify the Commercial Contributor in writing of such claim, and b) allow the Commercial Contributor to control, and cooperate with the Commercial Contributor in, the defense and any related settlement negotiations. The Indemnified Contributor may participate in any such claim at its own expense.

For example, a Contributor might include the Program in a commercial product offering, Product X. That Contributor is then a Commercial Contributor. If that Commercial Contributor then makes performance claims, or offers warranties related to Product X, those performance claims and warranties are such Commercial Contributor's responsibility alone. Under this section, the Commercial Contributor would have to defend claims against the other Contributors related to those performance claims and warranties, and if a court requires any other Contributor to pay any damages as a result, the Commercial Contributor must pay those damages.

5. NO WARRANTY

EXCEPT AS EXPRESSLY SET FORTH IN THIS AGREEMENT, THE PROGRAM IS PROVIDED ON AN "AS IS" BASIS, WITHOUT WARRANTIES OR CONDITIONS OF ANY KIND, EITHER EXPRESS OR IMPLIED INCLUDING, WITHOUT LIMITATION, ANY WARRANTIES OR CONDITIONS OF TITLE, NON-INFRINGEMENT, MERCHANTABILITY OR FITNESS FOR A PARTICULAR PURPOSE. Each Recipient is solely responsible for determining the appropriateness of using and distributing the Program and assumes all risks associated with its exercise of rights under this Agreement, including but not limited to the risks and costs of program errors, compliance with applicable laws, damage to or loss of data, programs or equipment, and unavailability or interruption of operations.

6. DISCLAIMER OF LIABILITY

EXCEPT AS EXPRESSLY SET FORTH IN THIS AGREEMENT, NEITHER RECIPIENT NOR ANY CONTRIBUTORS SHALL HAVE ANY LIABILITY FOR ANY DIRECT, INDIRECT, INCIDENTAL, SPECIAL, EXEMPLARY, OR CONSEQUENTIAL DAMAGES (INCLUDING WITHOUT LIMITATION LOST PROFITS), HOWEVER CAUSED AND ON ANY THEORY OF LIABILITY, WHETHER IN CONTRACT, STRICT LIABILITY, OR TORT (INCLUDING NEGLIGENCE OR OTHERWISE) ARISING IN ANY WAY OUT OF THE USE OR DISTRIBUTION OF THE PROGRAM OR THE EXERCISE OF ANY RIGHTS GRANTED HEREUNDER, EVEN IF ADVISED OF THE POSSIBILITY OF SUCH DAMAGES.

7. GENERAL

If any provision of this Agreement is invalid or unenforceable under applicable law, it shall not affect the validity or enforceability of the remainder of the terms of this Agreement, and without further action by the parties hereto, such provision shall be reformed to the minimum extent necessary to make such provision valid and enforceable.

If Recipient institutes patent litigation against any entity (including a cross-claim or counterclaim in a lawsuit) alleging that the Program itself (excluding combinations of the Program with other software or hardware) infringes such Recipient's patent(s), then such Recipient's rights granted under Section 2(b) shall terminate as of the date such litigation is filed.

All Recipient's rights under this Agreement shall terminate if it fails to comply with any of the material terms or conditions of this Agreement and does not cure such failure in a reasonable period of time after becoming aware of such noncompliance. If all Recipient's rights under this Agreement terminate, Recipient agrees to cease use and distribution of the Program as soon as reasonably practicable. However, Recipient's obligations under this Agreement and any licenses granted by Recipient relating to the Program shall continue and survive.

Everyone is permitted to copy and distribute copies of this Agreement, but in order to avoid inconsistency the Agreement is copyrighted and may only be modified in the following manner. The Agreement Steward

reserves the right to publish new versions (including revisions) of this Agreement from time to time. No one other than the Agreement Steward has the right to modify this Agreement. The Eclipse Foundation is the initial Agreement Steward. The Eclipse Foundation may assign the responsibility to serve as the Agreement Steward to a suitable separate entity. Each new version of the Agreement will be given a distinguishing version number. The Program (including Contributions) may always be distributed subject to the version of the Agreement under which it was received. In addition, after a new version of the Agreement is published, Contributor may elect to distribute the Program (including its Contributions) under the new version. Except as expressly stated in Sections 2(a) and 2(b) above, Recipient receives no rights or licenses to the intellectual property of any Contributor under this Agreement, whether expressly, by implication, estoppel or otherwise. All rights in the Program not expressly granted under this Agreement are reserved. This Agreement is governed by the laws of the State of New York and the intellectual property laws of the United States of America. No party to this Agreement will bring a legal action under this Agreement more than one year after the cause of action arose. Each party waives its rights to a jury trial in any resulting litigation.

8.6.6 GNU LESSER GENERAL PUBLIC LICENSE

Version 3, 29 June 2007

Copyright (C) 2007 Free Software Foundation, Inc. <<http://fsf.org/>>

Everyone is permitted to copy and distribute verbatim copies of this license document, but changing it is not allowed.

This version of the GNU Lesser General Public License incorporates the terms and conditions of version 3 of the GNU General Public License, supplemented by the additional permissions listed below.

0. Additional Definitions.

As used herein, “this License” refers to version 3 of the GNU Lesser General Public License, and the “GNU GPL” refers to version 3 of the GNU General Public License.

“The Library” refers to a covered work governed by this License, other than an Application or a Combined Work as defined below.

An “Application” is any work that makes use of an interface provided by the Library, but which is not otherwise based on the Library. Defining a subclass of a class defined by the Library is deemed a mode of using an interface provided by the Library.

A “Combined Work” is a work produced by combining or linking an Application with the Library. The particular version of the Library with which the Combined Work was made is also called the “Linked Version”.

The “Minimal Corresponding Source” for a Combined Work means the Corresponding Source for the Combined Work, excluding any source code for portions of the Combined Work that, considered in isolation, are based on the Application, and not on the Linked Version.

The “Corresponding Application Code” for a Combined Work means the object code and/or source code for the Application, including any data and utility programs needed for reproducing the Combined Work from the Application, but excluding the System Libraries of the Combined Work.

1. Exception to Section 3 of the GNU GPL.

You may convey a covered work under sections 3 and 4 of this License without being bound by section 3 of the GNU GPL.

2. Conveying Modified Versions.

If you modify a copy of the Library, and, in your modifications, a facility refers to a function or data to be supplied by an Application that uses the facility (other than as an argument passed when the facility is invoked), then you may convey a copy of the modified version:

- a) under this License, provided that you make a good faith effort to ensure that, in the event an Application does not supply the function or data, the facility still operates, and performs whatever part of its purpose remains meaningful, or
- b) under the GNU GPL, with none of the additional permissions of this License applicable to that copy.

3. Object Code Incorporating Material from Library Header Files.

The object code form of an Application may incorporate material from a header file that is part of the Library. You may convey such object code under terms of your choice, provided that, if the incorporated material is not limited to numerical parameters, data structure layouts and accessors, or small macros, inline functions and templates (ten or fewer lines in length), you do both of the following:

- a) Give prominent notice with each copy of the object code that the Library is used in it and that the Library and its use are covered by this License.
- b) Accompany the object code with a copy of the GNU GPL and this license document.

4. Combined Works.

You may convey a Combined Work under terms of your choice that, taken together, effectively do not restrict modification of the portions of the Library contained in the Combined Work and reverse engineering for debugging such modifications, if you also do each of the following:

- a) Give prominent notice with each copy of the Combined Work that the Library is used in it and that the Library and its use are covered by this License.
- b) Accompany the Combined Work with a copy of the GNU GPL and this license document.
- c) For a Combined Work that displays copyright notices during execution, include the copyright notice for the Library among these notices, as well as a reference directing the user to the copies of the GNU GPL and this license document.
- d) Do one of the following:

0) Convey the Minimal Corresponding Source under the terms of this License, and the Corresponding Application Code in a form suitable for, and under terms that permit, the user to recombine or relink the Application with a modified version of the Linked Version to produce a modified Combined Work, in the manner specified by section 6 of the GNU GPL for conveying Corresponding Source.

1) Use a suitable shared library mechanism for linking with the Library. A suitable mechanism is one that (a) uses at run time a copy of the Library already present on the user's computer system, and (b) will operate properly with a modified version of the Library that is interface-compatible with the Linked Version.

e) Provide Installation Information, but only if you would otherwise be required to provide such information under section 6 of the GNU GPL, and only to the extent that such information is necessary to install and execute a modified version of the Combined Work produced by recombining or relinking the Application with a modified version of the Linked Version. (If you use option 4d0, the Installation Information must accompany the Minimal Corresponding Source and Corresponding Application Code. If you use option 4d1, you must provide the Installation Information in the manner specified by section 6 of the GNU GPL for conveying Corresponding Source.)

5. Combined Libraries.

You may place library facilities that are a work based on the Library side by side in a single library together with other library facilities that are not Applications and are not covered by this License, and convey such a combined library under terms of your choice, if you do both of the following:

a) Accompany the combined library with a copy of the same work based on the Library, uncombined with any other library facilities, conveyed under the terms of this License.

b) Give prominent notice with the combined library that part of it is a work based on the Library, and explaining where to find the accompanying uncombined form of the same work.

6. Revised Versions of the GNU Lesser General Public License.

The Free Software Foundation may publish revised and/or new versions of the GNU Lesser General Public License from time to time. Such new versions will be similar in spirit to the present version, but may differ in detail to address new problems or concerns.

Each version is given a distinguishing version number. If the Library as you received it specifies that a certain numbered version of the GNU Lesser General Public License “or any later version” applies to it, you have the option of following the terms and conditions either of that published version or of any later version published by the Free Software Foundation. If the Library as you received it does not specify a version number of the GNU Lesser General Public License, you may choose any version of the GNU Lesser General Public License ever published by the Free Software Foundation.

If the Library as you received it specifies that a proxy can decide whether future versions of the GNU Lesser General Public License shall apply, that proxy's public statement of acceptance of any version is permanent authorization for you to choose that version for the Library.

8.6.7 Google Web Toolkit

Google Web Toolkit is licensed under Apache License version 2.0. See above.

8.6.8 X11 license (MIT license)

Permission is hereby granted, free of charge, to any person obtaining a copy of this software and associated documentation files (the "Software"), to deal in the Software without restriction, including without limitation the rights to use, copy, modify, merge, publish, distribute, sublicense, and/or sell copies of the Software, and to permit persons to whom the Software is furnished to do so, subject to the following conditions:

The above copyright notice and this permission notice shall be included in all copies or substantial portions of the Software.

THE SOFTWARE IS PROVIDED "AS IS", WITHOUT WARRANTY OF ANY KIND, EXPRESS OR IMPLIED, INCLUDING BUT NOT LIMITED TO THE WARRANTIES OF MERCHANTABILITY, FITNESS FOR A PARTICULAR PURPOSE AND NONINFRINGEMENT. IN NO EVENT SHALL THE AUTHORS OR COPYRIGHT HOLDERS BE LIABLE FOR ANY CLAIM, DAMAGES OR OTHER LIABILITY, WHETHER IN AN ACTION OF CONTRACT, TORT OR OTHERWISE, ARISING FROM, OUT OF OR IN CONNECTION WITH THE SOFTWARE OR THE USE OR OTHER DEALINGS IN THE SOFTWARE.



About Us

Nanometrics is an award winning company providing monitoring solutions and equipment for studying man-made and natural seismicity. Headquartered in Ottawa, Ontario, with offices and representatives world-wide, Nanometrics has over 30 years' experience, delivering solutions to customers across the globe. Nanometrics real-time and portable systems are utilized by the world's leading scientific institutions, universities and major corporations. Our pedigree is founded on precision instrumentation, network technology and software applications for seismological and environmental research. We specialize in collecting and analyzing critical real time data for global, regional and local seismic networks. We deliver world-class network design, installation and training services throughout the globe in a safety conscious environment.

Contact Us

Nanometrics Inc.

*250 Herzberg Road
Kanata, ON K2K 2A1
Canada*

Phone: +1 613-592-6776

Toll free: +1 855-792-6776 (within North America)

Fax: +1 613-592-5929

Email: sales_mkt@nanometrics.ca

Web: www.nanometrics.ca

Technical Support

If you need technical support please submit a request on the Nanometrics technical support site or by email or fax. Include a full explanation of the problem and related information such as log files.

Support site: <http://support.nanometrics.ca/>

Email: techsupport@nanometrics.ca